

## Datasheet

### AC Control Air for Sinclair

Part Nr: 100587

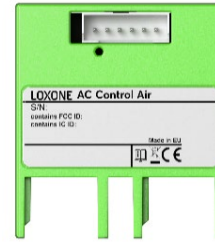

#### About the product

With the AC Control Air for Sinclair you can integrate Sinclair air conditioners easily, quickly and seamlessly into your Loxone installation. Intelligent control of the air conditioners can significantly increase comfort and reduce energy consumption by more than 30% at the same time. This saves costs and protects the planet.

No additional power supply necessary  
Simple commissioning via Plug & Play  
very compact design: 38.3x34.3x10.5mm  
incl. full user interface and control in the Loxone App

#### Technical Data

Power supply	via AC unit
Power consumption	typ. 0.3W, max. 0.6W
Loxone Air interface	868MHz (SRD Band Europe), 4 channels, max. 15.1mW e.r.p. 915MHz (ISM Band Region 2), 10 channels, max. 13.2mW internal antenna
Ambient temperature	-20 ... 65°C / -4 ... 149°F
Humidity	max. 95% r.H. (non condensing)
Degree of protection	IP20

#### Connecting cable

Wire cross-section	0.14mm <sup>2</sup> / AWG26
Temperature resistance	80°C / 176°F
Length	300mm / 11.81"
Part. No.	000581

## Connection Diagram

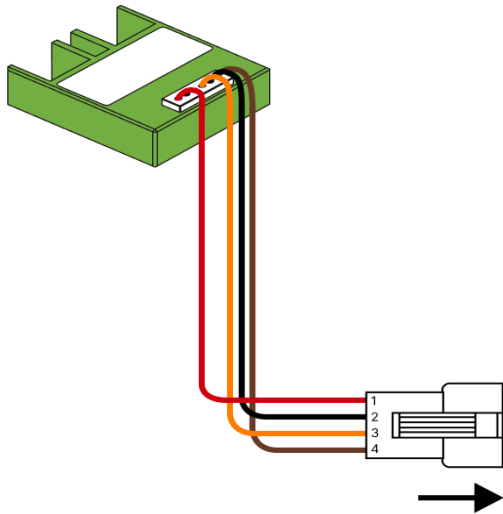

## Air conditioning unit

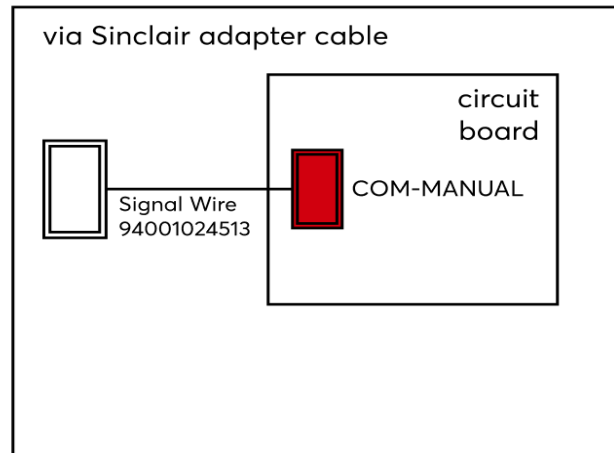

## Product Characteristics

Colours	Green RAL6018
Finish	Matte

## Weight & Dimensions

Net weight	54g
Total weight	74g
Product dimensions	38.3x34.3x10.5mm / 1.50x1.35x0.41" (LxWxH)

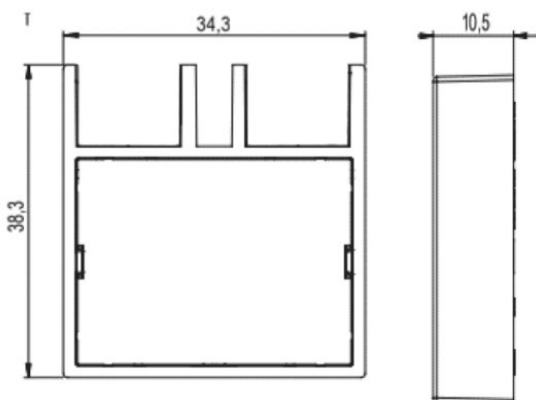

Pack size	79x79x41mm / 3.11x3.11x1.61" (LxWxH)
-----------	--------------------------------------

## Certifications & Standards

Certifications



An up-to-date List of compatible AC units is available online: [shop.loxone.com/ac-control/](https://shop.loxone.com/ac-control/)

Installation must be carried out by a qualified electrician in accordance with the relevant regulations. Installation may only be carried out with the power supply to the air conditioner switched off.

### Published by

#### Loxone Electronics GmbH

Smart Home 1  
4154 Kollerschlag  
Austria  
Tel: +43 7287 7070-0  
[loxone.com](https://www.loxone.com)

#### Loxone UK

The Forum,  
Station Road,  
Theale, RG7 4RA

## Datenblatt

### AC Control Air für Sinclair

Art. Nr. 100587

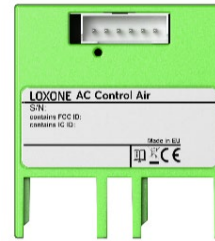

#### Information zum Produkt

Mit dem AC Control Air für Sinclair binden Sie Sinclair Klimaanlage einfach, schnell und nahtlos in Ihre Loxone Installation ein. Durch die intelligente Ansteuerung der Klimageräte lässt sich der Komfort deutlich erhöhen und der Energieverbrauch gleichzeitig um mehr als 30% senken. Das spart Kosten und schont den Planeten.

keine zusätzliche Spannungsversorgung nötig

Einfache Inbetriebnahme via Plug & Play

Sehr kompakte Bauweise: 38,3x34,3x10,5mm

inkl. voller Visualisierung und Steuerung in der Loxone App

#### Technische Daten

Spannungsversorgung	von Klimaanlage
Leistungsaufnahme	typ. 0,3W, max. 0,6W
Loxone Air Schnittstelle	868MHz (SRD Band Europa), 4 Kanäle, max. 15.1mW e.r.p. 915MHz (ISM Band Region 2), 10 Kanäle, max. 13.2mW interne Antenne
Umgebungstemperatur	-20 ... 65°C / -4 ... 149°F
Luftfeuchtigkeit	max. 95% r.H. (nicht kondensierend)
Schutzart	IP20

#### Verbindungskabel

Leiterquerschnitt	0,14mm <sup>2</sup> / AWG26
Temperaturbeständigkeit	80°C / 176°F
Länge	300mm / 11,811"
Art. Nr.	000581

## Anschlussplan

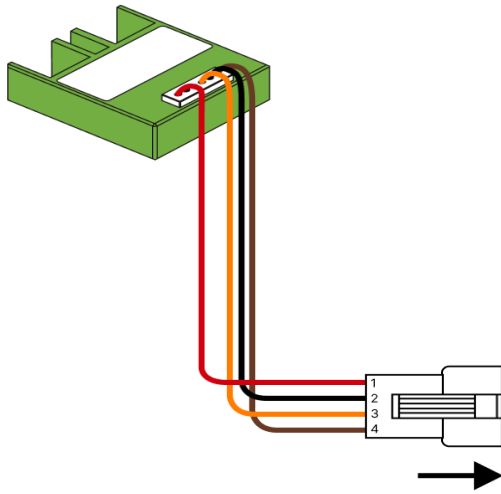

## Air conditioning unit

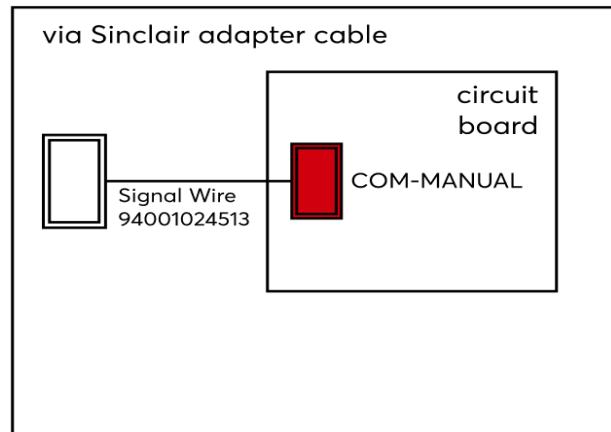

## Produkteigenschaften

Farbe	Grün RAL6018
Glanzgrad	Matt

## Gewicht & Abmessungen

Nettogewicht	54g
Bruttogewicht	74g
Produktmaße	38,3x34,3x10,5mm / 1,50x1,35x0,41" (LxBxH)

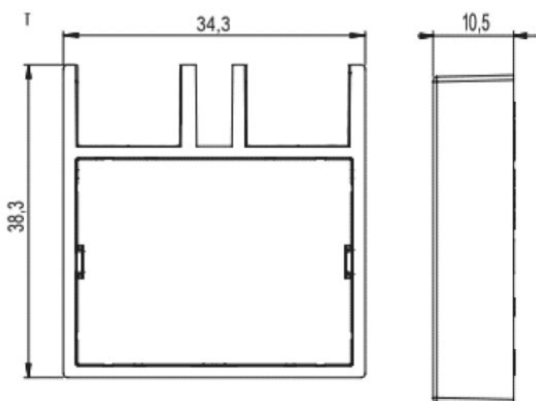

Packmaß	79x79x41mm / 3,11x3,11x1,61" (LxBxH)
---------	--------------------------------------

## Zertifizierungen & Standards

Zertifizierungen



Eine aktuelle Liste der kompatiblen Klimaanlage ist online verfügbar: [shop.loxone.com/ac-control](https://shop.loxone.com/ac-control)

Die Installation muss nach den einschlägigen Vorschriften durch eine Elektrofachkraft erfolgen.  
Die Installation darf nur im spannungslosen Zustand der Klimaanlage durchgeführt werden!

**Published by**  
**Loxone Electronics GmbH**  
Smart Home 1  
4154 Kollerschlag  
Austria  
Tel: +43 7287 7070-0  
[loxone.com](https://loxone.com)

**Loxone UK**  
The Forum,  
Station Road,  
Theale, RG7 4RA