

Datasheet

Touch Surface Air

Part No: 100285



About the product

The LOXONE Touch Surface Air has **six touch points** for operating the most important functions in a room. When a button is **touched**, LEDs light up and a click sounds as **acoustic confirmation**. **The device can be mounted under a non-conductive surface up to 30mm thick; touch detection occurs through the material. Stone, wood, ceramic or glass can be used.**

Electrical Specifications

Supply voltage	9 ... 28 V DC or Loxone Battery Pack
Power consumption	external power supply: typ. 0.067 W, max. 0.133 W battery powered: typ. 0.00025 W, max. 0.1 W
Power loss at max. load	0.133 W
Battery Lifetime	up to 2 years

Interfaces

LOXONE Air	868 MHz (SRD Band Europe), 4 channels, max. 15.1 mW e.r.p. 915 MHz (ISM Band Region 2), 10 channels, max. 13.2 mW internal antenna
------------	--

Operating Elements

Touch points (6)	capacitive touch detection
Click feedback	Yes

Ambient Conditions

Temperature	external power supply: -20 ... 70 °C / -4 ... 158 °F battery powered: -20 ... 54 °C / -4 ... 129 °F
Humidity	max. 95 % RH (non-condensing)
Ingress protection	IP20

Connection Terminals

Terminal type	DG220B
Wire cross-section	0.28 ... 0.8 mm ² / AWG 23 ... 18
Stripping length	5 ... 6 mm / 0.2 ... 0.24"
Temperature resistance	-40 ... 105 °C / -40 ... 221 °F

Connection Diagram

Connection Diagram

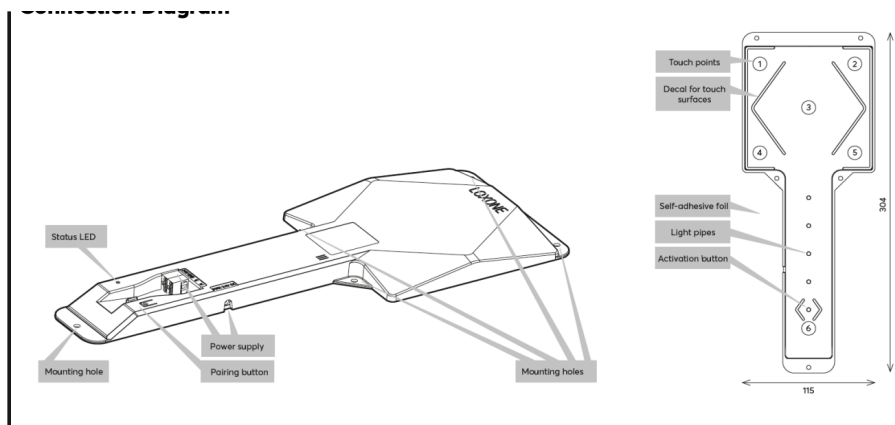

Product Characteristics

Colours	White: RAL 9003
Finish	Matte
Surface material	Stone, Wood, Ceramic or Glass – Please note that this product will not work with conductive materials. max. 30mm / 1.18"

Weight & Dimensions

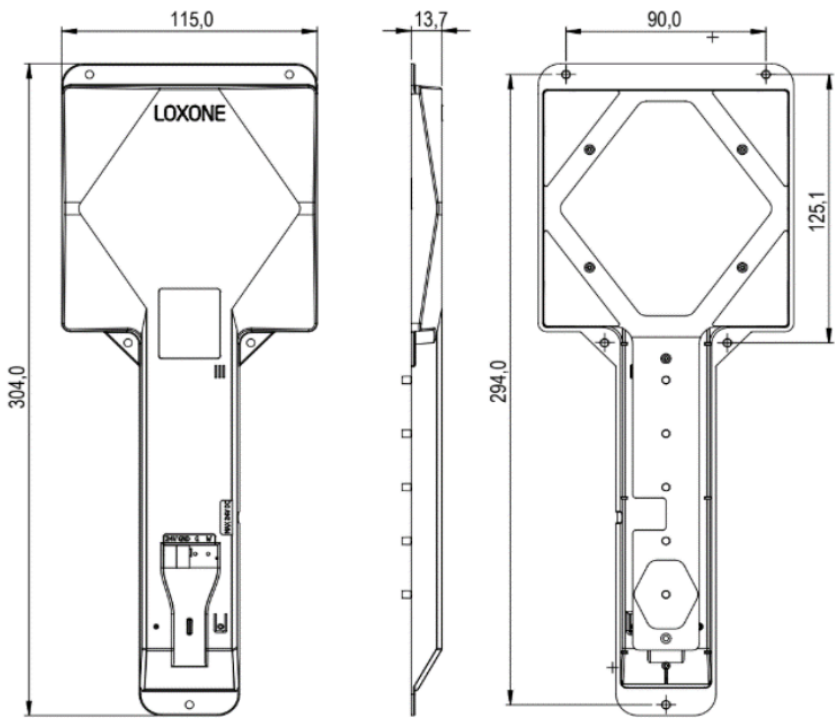
Net weight	173 g
Total weight	288 g
Product dimensions	304 x 115 x 18 mm / 12 x 4.53 x 0.71" (L x W x H)
Product dimensions drawing	
Pack size	340 x 155 x 30 mm / 13.39 x 6.10 x 1.18" (L x W x H)

Certifications & Standards



Installation must be carried out by a qualified electrician in accordance with the relevant regulations.

Published by

Loxone Electronics GmbH
Smart Home 1
4154 Kollerschlag
Austria
Tel: +43 7287 7070-0
loxone.com

Loxone UK Ltd.
The Forum
Station Road
Theale, RG7 4RA
United Kingdom

Datenblatt

Touch Surface Air

Part No: 100285



Über das Produkt

Der LOXONE Touch Surface Air verfügt über **sechs Tastpunkte** zur Bedienung der wichtigsten Funktionen eines Raumes. Bei **Berührung** einer Taste erfolgt ein **Aufleuchten von LEDs** und ein Klicken als **akustische Bestätigung**. Das Gerät kann unter einer **nicht leitenden Fläche** von bis zu 30mm Stärke **montiert** werden, die Berührungserkennung erfolgt durch das Material hindurch. Es kann Stein, Holz, Keramik oder Glas zum Einsatz kommen.

Elektrische Spezifikationen

Versorgungsspannung	9 ... 28 V DC oder Loxone Battery Pack
Leistungsaufnahme	externe Spannungsversorgung: typ. 0,067 W, max. 0,133 W batterieversorgt: typ. 0,00025 W, max. 0,1 W
Verlustleistung bei max. Last	0,133 W
Batterie Lebensdauer	bis zu 2 Jahre

Schnittstellen

LOXONE Air	868 MHz (SRD Band Europa), 4 Kanäle, max. 15,1 mW e.r.p. 915 MHz (ISM Band Region 2), 10 Kanäle, max. 13,2 mW interne Antenne
------------	---

Bedienelemente

Tastpunkte (6)	kapazitive Berührungserkennung
Klick Feedback	Ja

Umgebungsbedingungen

Temperatur	externe Spannungsversorgung: -20 ... 70 °C / -4 ... 158 °F batterieversorgt: -20 ... 54 °C / -4 ... 129 °F
Luftfeuchtigkeit	max. 95 % r. F. (nicht kondensierend)
Schutzart	IP20

Anschlussklemmen

Klemmentyp	DG220B
Leiterquerschnitt	0,28 ... 0,8 mm ² / AWG 23 ... 18
Abisolierlänge	5 ... 6 mm / 0,2 ... 0,24"
Temperaturbeständigkeit	-40 ... 105 °C / -40 ... 221 °F

Anschlussplan

Anschlussplan

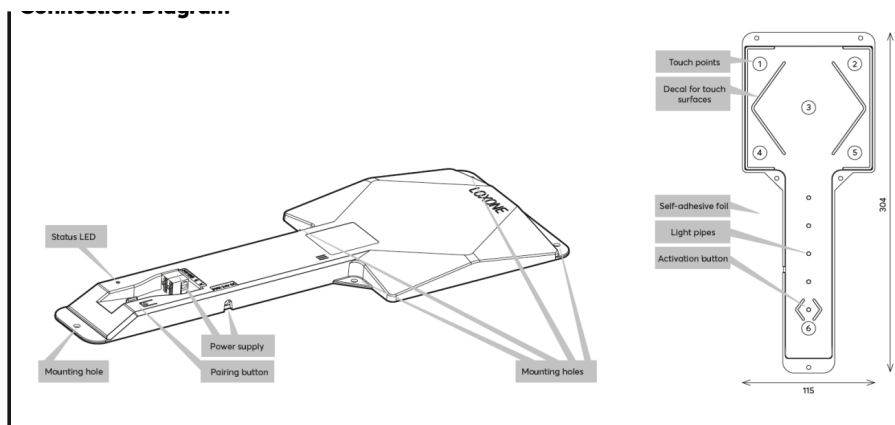

Produkteigenschaften

Farbe	Weiß: RAL 9003
Glanzgrad	Matt
Oberflächenmaterial	Stein, Holz, Keramik oder Glas - Bitte beachten Sie, dass dieses Produkt mit leitfähigen Materialien nicht funktioniert. max. 30mm / 1,18"

Gewicht & Abmessungen

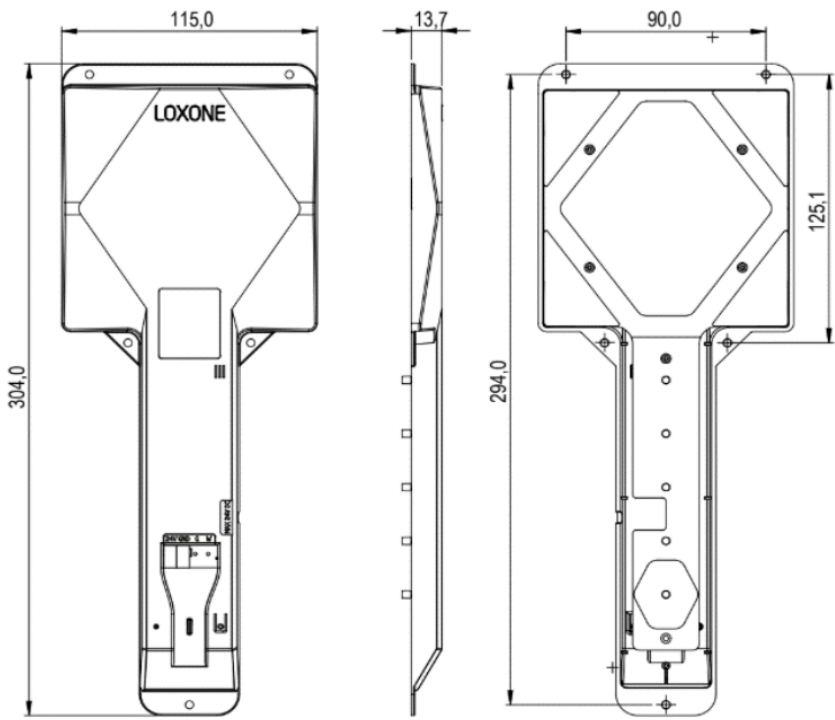
Nettogewicht	173 g
Bruttogewicht	288 g
Produktmaße	304 x 115 x 18 mm / 12 x 4,53 x 0,71" (L x B x H)
Produktmaßzeichnung	
Packmaß	340 x 155 x 30 mm / 13.39 x 6.10 x 1.18" (L x B x H)

Zertifizierungen & Standards



Die Installation muss von einer qualifizierten Elektrofachkraft gemäß den einschlägigen Vorschriften durchgeführt werden.

Veröffentlicht von

Loxone Electronics GmbH
Smart Home 1
4154 Kollerschlag
Austria
Tel: +43 7287 7070-0
loxone.com

Loxone UK Ltd.
The Forum
Station Road
Theale, RG7 4RA
United Kingdom