

Datasheet

Alarm Siren Air

Part No: 100312

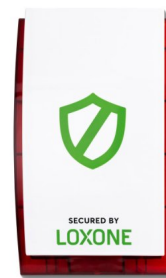

About the product

The LOXONE Alarm Siren Air serves as an **external warning device** and **alarms** when activated with a **loud alarm tone** and a **red flashing light**. The integrated **tamper switch** offers additional protection. Quick commissioning thanks to LOXONE Air.

Electrical Specifications

Supply voltage	18 ... 28 VDC
Power consumption	typ. 0.065 W, max. 6.7 W
Power loss	max. 6.7W
LOXONE Air	868MHz (SRD Band Europe), 4 channels available 915MHz (ISM Band Region 2), 10 channels available max. Power 3.16mW
Temperature	-40 ... 55°C / -40 ... 131°F
Alarm	Acoustic 93dB / 1m 83.5dB / 3m optical: flashing red light
Tamper detection	Yes

Ambient Conditions

Humidity	max. 95% r.H. (non condensing)
----------	--------------------------------

Connections

Wire cross-section	0.4 ... 0.8mm ² / AWG26 ... 19
Stripping length	must not be stripped
Temperature resistance	-40 ... 140 °C / -40 ... 284°F

Connection Diagram

Connection Diagram

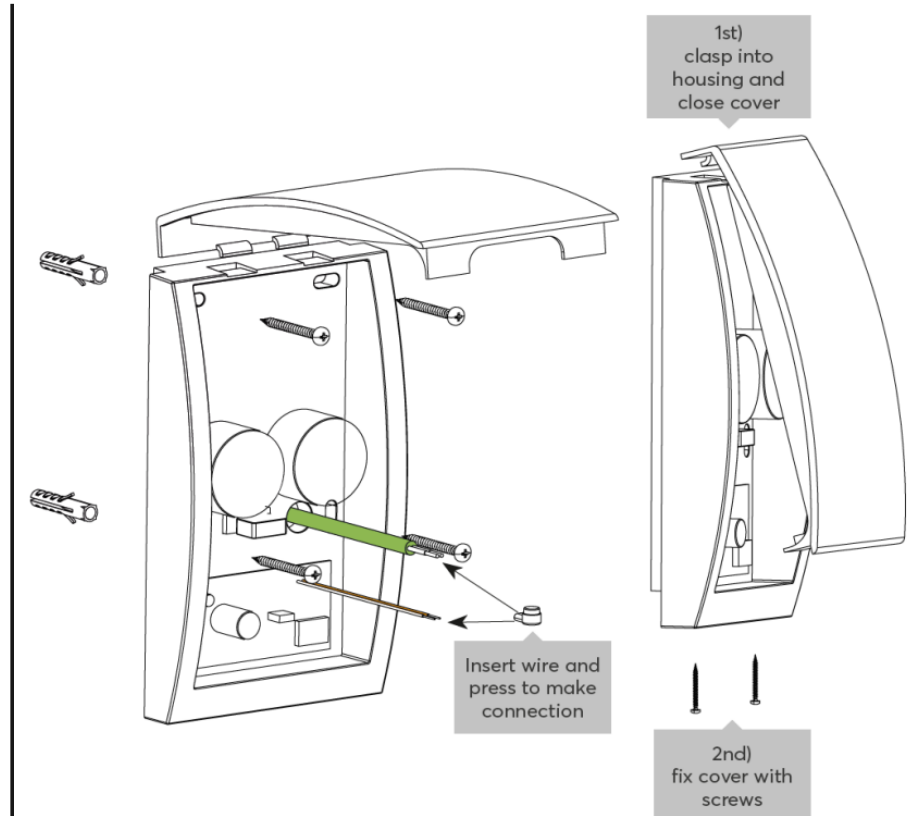

Product Characteristics

Colours

White: RAL 9003

Finish

Matte

Weight & Dimensions

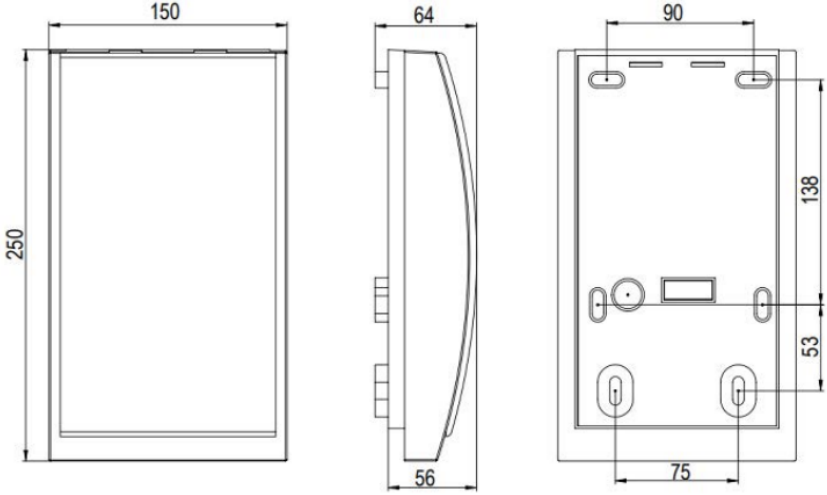
Net weight	585g
Total weight	665 g
Product dimensions	250x150x64mm / 9.84x5.91x2.52" (LxWxH)
Product dimensions	 <p>The technical drawings show three views of the device: a front view with dimensions 150mm width and 250mm height; a side view with a total thickness of 64mm and a base width of 56mm; and a top view with a width of 90mm, a height of 138mm, and a central width of 75mm. The top view also shows the positions of various components like screws and a central slot.</p>
Pack size	255x155x70mm / 10.03x6.10x2.75" (LxWxH)

Certifications & Standards

Safety class	IP44
Certifications	 <p>The certifications shown are the CE mark and the UKCA mark, indicating compliance with European and United Kingdom standards.</p>

Installation must be carried out by a qualified electrician in accordance with the relevant regulations.

Published by

Loxone Electronics GmbH
Smart Home 1
4154 Kollerschlag
Austria
Tel: +43 7287 7070-0
loxone.com

Loxone UK Ltd.
The Forum
Station Road
Theale, RG7 4RA
United Kingdom

Datenblatt

Alarmsirene Air

Part No: 100312



Über das Produkt

Die LOXONE Alarmsirene Air dient als **externe Warneinrichtung**, und **alarmiert** bei Aktivierung über einen **lauten Alarmton**, sowie ein **rotes Blitzlicht**. Der integrierte **Sabotageschalter** bietet zusätzlichen Schutz. Schnelle Inbetriebnahme dank LOXONE Air.

Elektrische Spezifikationen

Versorgungsspannung	18 ... 28 VDC
Leistungsaufnahme	typ. 0,065 W, max. 6,7 W
Verlustleistung	max. 6,7W
LOXONE Air	868MHz (SRD Band Europa), 4 Kanäle wählbar 915MHz (ISM Band Region 2), 10 Kanäle wählbar max. Sendeleistung 3,16mW
Temperatur	-40 ... 55°C / -40 ... 131°F
Alarm	Akustisch: 93dB / 1m 83,5dB / 3m optisch: rotes Blitzlicht
Sabotageschutz	Ja

Umgebungsbedingungen

Luftfeuchtigkeit	max. 95% r.H. (nicht kondensierend)
------------------	-------------------------------------

Anschlüsse

Leiterquerschnitt	0.4 ... 0.8mm ² / AWG26 ... 19
Abisolierlänge	darf nicht abisoliert werden
Temperaturbeständigkeit	-40 ... 140 °C / -40 ... 284°F

Anschlussplan

Anschlussplan

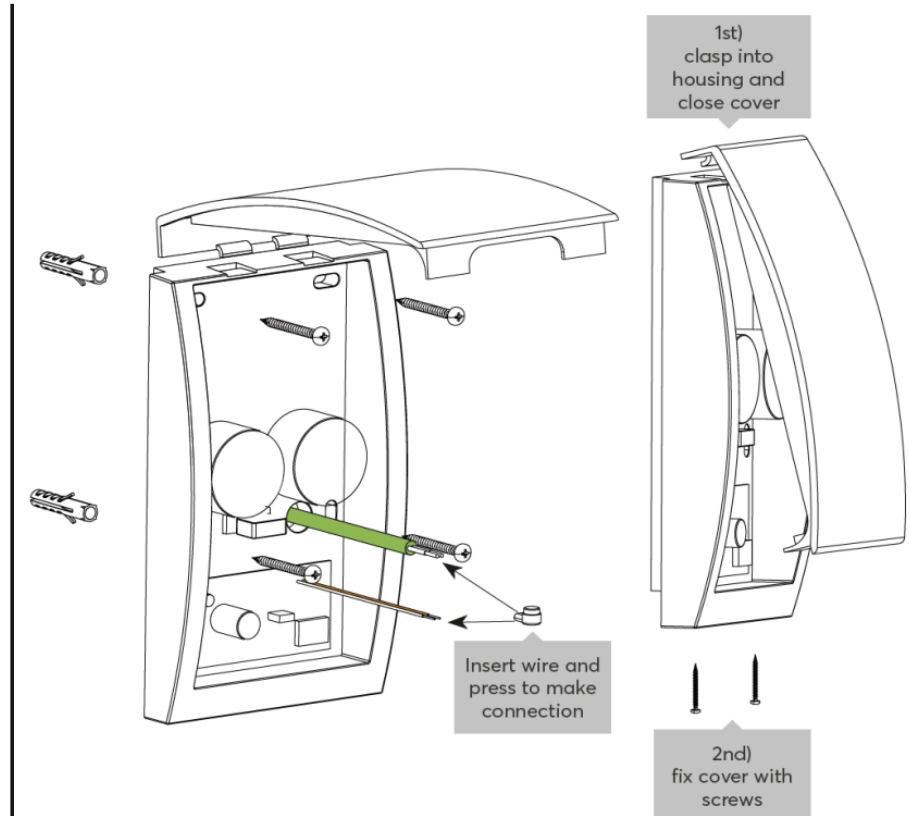

Produkteigenschaften

Farbe

Weiß: RAL 9003

Glanzgrad

Matt

Gewicht & Abmessungen

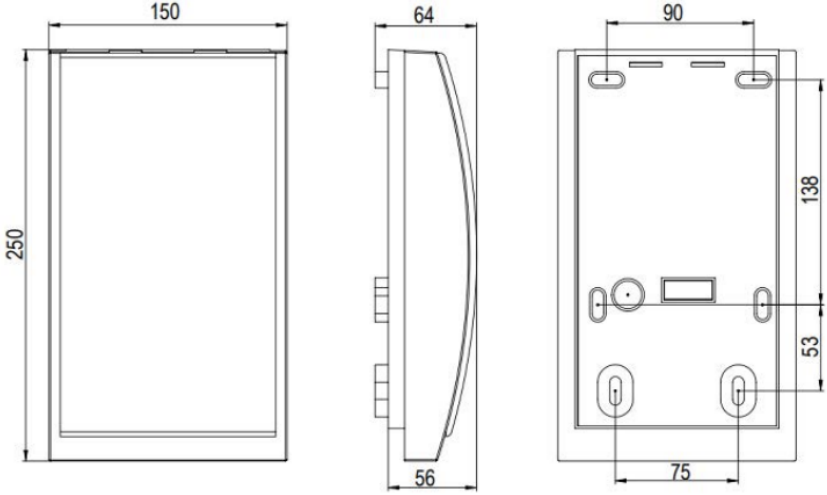
Nettogewicht	585g
Bruttogewicht	665 g
Produktmaße	250x150x64mm / 9.84x5.91x2.52" (LxWxH)
Produktmaße	 <p>The technical drawings show three views of the device: a front view with dimensions 150mm width and 250mm height; a side view with a total thickness of 64mm and a base width of 56mm; and a top view with a width of 90mm and a height of 138mm. The top view also shows a central width of 75mm and a distance of 53mm from the bottom edge to the center of the device.</p>
Packmaß	255x155x70mm / 10.03x6.10x2.75" (LxWxH)

Zertifizierungen & Standards

Schutzklasse	IP44
Zertifizierungen	 <p>The image shows two certification logos: the CE mark and the UKCA mark.</p>

Die Installation muss von einer qualifizierten Elektrofachkraft gemäß den einschlägigen Vorschriften durchgeführt werden.

Veröffentlicht von

Loxone Electronics GmbH
Smart Home 1
4154 Kollerschlag
Austria
Tel: +43 7287 7070-0
loxone.com

Loxone UK Ltd.
The Forum
Station Road
Theale, RG7 4RA
United Kingdom