

Datasheet

Schüco Extension

Part No: 100457



About the product

The LOXONE Schüco Extension enables the integration of **devices with the Schüco element bus.**

Features:

- For the integration of max. 30 devices
- Full integration of Schüco TipTronic SimplySmart windows and sliding doors into the intelligent building

Electrical Specifications

Supply voltage	9 ... 28 V DC
Power consumption	max. 0.06 W
Power loss at max. load	0.06 W

Interfaces

LOXONE Link	Connection with Miniserver
Schüco Unit Bus	max. 30 devices max. 500 m wire length

Supported Devices

Device Types and Models	TipTronic OL/Tilt TipTronic Turn LS TipTronic Turn RS TipTronic TurnTilt LS TipTronic TurnTilt RS TipTronic TopHung TipTronic OpenOut TopHung TipTronic OpenOut PAF (Master) TipTronic OpenOut PAF (Slave) TipTronic NRWG Tilt TipTronic NRWG Turn LS TipTronic NRWG Turn RS TipTronic NRWG TopHung TipTronic NRWG OpenOut TopHung Sliding Door ASE 60/80
-------------------------	---

Ambient Conditions

Temperature	-40 ... 70 °C / -40 ... 158 °F
Humidity	max. 95 % RH (non-condensing)
Ingress protection	IP20

Connection Terminals

Terminal type	24 VDC & LOXONE Link	Interface
		DG220B
Wire cross-section	0.25 ... 0.8 mm ² / AWG 23 ... 18	0.8 mm ² / AWG 18
Stripping length	5 mm / 0.2"	7 mm / 0.28"
Temperature resistance	-40 ... 105 °C / -40 ... 221 °F	min. 80 °C / 176 °F for IEC, min. 75 °C / 167 °F for UL

Connection Diagram

Connection Diagram

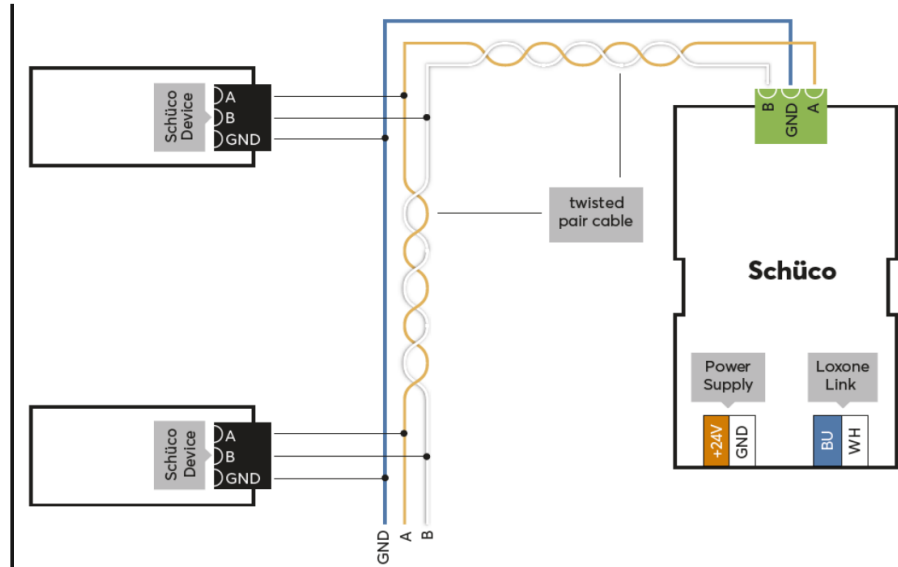

Product Characteristics

Mounting type | DIN rail according to EN 50022, 35 mm

Colours | Black: RAL 9005

Finish | Matte

Weight & Dimensions

Net weight | 65 g

Total weight | 85 g

Product dimensions | 88 x 35.4 x 57 mm / 3.46 x 1.39 x 2.24" (L x W x H), 2 division units

Product dimensions drawing

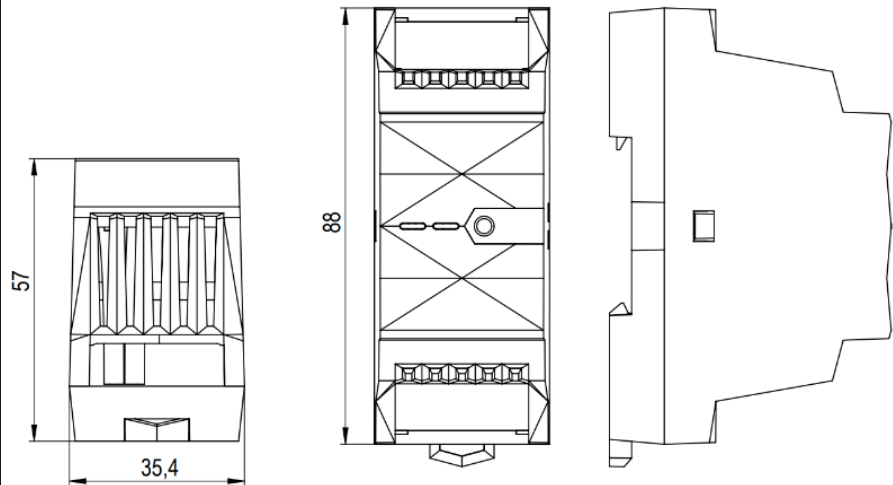

Pack size | 121 x 38 x 62 mm / 4.76 x 1.50 x 2.44" (L x W x H)

Certifications & Standards



Installation must be carried out by a qualified electrician in accordance with the relevant regulations.

Published by

Loxone Electronics GmbH
Smart Home 1
4154 Kollerschlag
Austria
Tel: +43 7287 7070-0
loxone.com

Loxone UK Ltd.
The Forum
Station Road
Theale, RG7 4RA
United Kingdom

Datenblatt

Schüco Extension

Part No: 100457



Über das Produkt

Die LOXONE Schüco Extension ermöglicht die Einbindung von **Geräten mit dem Schüco Elementbus**.

Features:

- Zur Einbindung von max. 30 Geräten
- Vollständige Integration von Schüco TipTronic SimplySmart Fenster- & Schiebetüren in das intelligente Gebäude

Elektrische Spezifikationen

Versorgungsspannung	9 ... 28 V DC
Leistungsaufnahme	max. 0,06 W
Verlustleistung bei max. Last	0,06 W

Schnittstellen

LOXONE Link	Verbindung mit Miniserver
Schüco Elementbus	max. 30 Geräte max. 500 m Kabellänge

Unterstützte Geräte

Gerätearten und Modelle	TipTronic OL/Tilt TipTronic Turn LS TipTronic Turn RS TipTronic TurnTilt LS TipTronic TurnTilt RS TipTronic TopHung TipTronic OpenOut TopHung TipTronic OpenOut PAF (Master) TipTronic OpenOut PAF (Slave) TipTronic NRWG Tilt TipTronic NRWG Turn LS TipTronic NRWG Turn RS TipTronic NRWG TopHung TipTronic NRWG OpenOut TopHung Sliding Door ASE 60/80
-------------------------	---

Umgebungsbedingungen

Temperatur	-40 ... 70°C / -40 ... 158°F
Luftfeuchtigkeit	max. 95 % r. F. (nicht kondensierend)
Schutzart	IP20

Anschlussklemmen

Klemmentyp	24 VDC & LOXONE Link	Schnittstelle
	DG220B	-
Leiterquerschnitt	0,25 ... 0,8 mm ² / AWG 23 ... 18	0,8 mm ² / AWG 18
Abisolierlänge	5 mm / 0,2"	7 mm / 0,28"
Temperaturbeständigkeit	-40 ... 105 °C / -40 ... 221 °F	min. 80 °C / 176 °F für IEC, min. 75 °C / 167 °F für UL

Anschlussplan

Anschlussplan

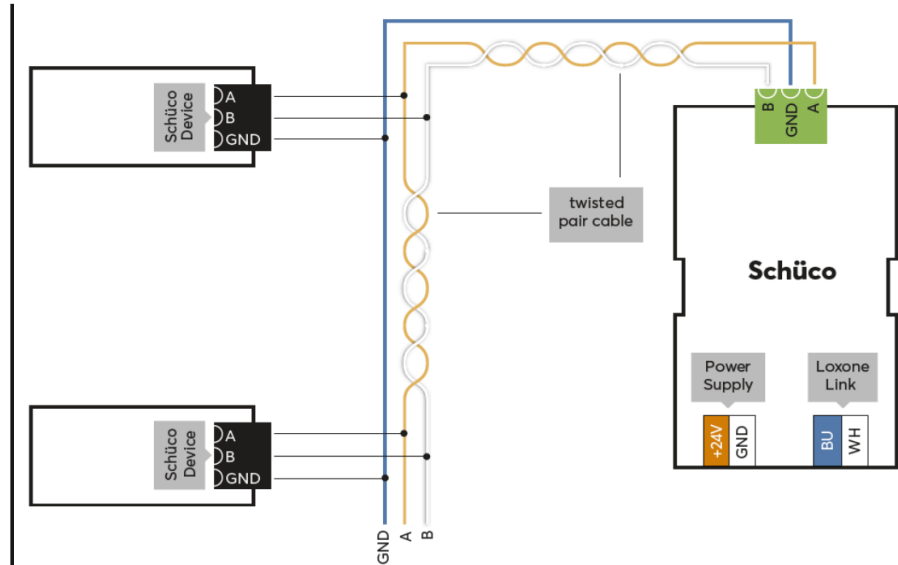

Produkteigenschaften

Montageart Hutschiene nach EN50022, 35 mm

Farbe Schwarz: RAL 9005

Glanzgrad Matt

Gewicht & Abmessungen

Nettogewicht 65 g

Bruttogewicht 85 g

Produktmaße 88 x 35,4 x 57 mm / 3,46 x 1,39 x 2,24" (L x B x H), 2 Teilungseinheiten

Produktmaßzeichnung

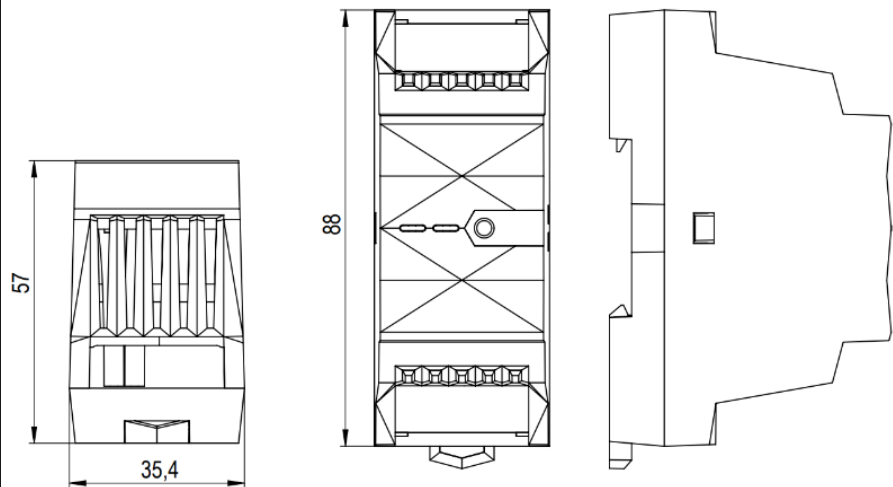

Packmaß 121 x 38 x 62 mm / 4,76 x 1,50 x 2,44" (L x B x H)

Zertifizierungen & Standards



Die Installation muss von einer qualifizierten Elektrofachkraft gemäß den einschlägigen Vorschriften durchgeführt werden.

Veröffentlicht von

Loxone Electronics GmbH
Smart Home 1
4154 Kollerschlag
Austria
Tel: +43 7287 7070-0
loxone.com

Loxone UK Ltd.
The Forum
Station Road
Theale, RG7 4RA
United Kingdom