

Datasheet

Touch Pure Classic

Tree Signal White

Part No: 100461



About the product

The LOXONE Touch Pure Tree has **five touch points** on a glass front for operating the most important functions in a room. When a button is touched, a click is heard as **acoustic confirmation**.

Features:

- A control element for controlling lighting, shading, audio and more
- Integrated temperature and humidity sensor for controlling the room climate
- Integrated orientation light
- High-quality feel and appearance
- Easy installation thanks to LOXONE Tree technology

For the best user experience in your projects, we recommend: Switch to [the new Touch Pure](#) now. The revised design offers maximum user-friendliness and fits perfectly into modern interiors.

Electrical Specifications

Supply voltage	6 ... 30 VDC
Power consumption	typ. 0.049 W, max. 0.095 W
Power loss	max. 95mW
Temperature	-20 ... 70°C / -4 ... 158°F
Touch points	5 touch points, capacitive touch detection
Temperature detection range	-40 ... 125°C / -40 ... 257°F; +/- 0.5°C / 0.9°F
Humidity detection range	0 ... 100% r.H. +/- 2%, (non condensing)
Orientation light	Yes
Recommended mounting height	135cm / 53.15"

Interfaces

LOXONE Tree	connection with Miniserver / Tree Extension
-------------	---

Ambient Conditions

Humidity	max. 95% r.H. (non condensing)
----------	--------------------------------

Operating Elements

Click feedback	Yes
----------------	-----

Connection Terminals

Wire cross-section	0.25 ... 0.8 mm ² / AWG 23 ... 18
--------------------	--

Stripping length	5 mm / 0.2"
------------------	-------------

Temperature resistance	-40 ... 105°C / -40 ... 221°F
------------------------	-------------------------------

Connection Diagram

Connection Diagram

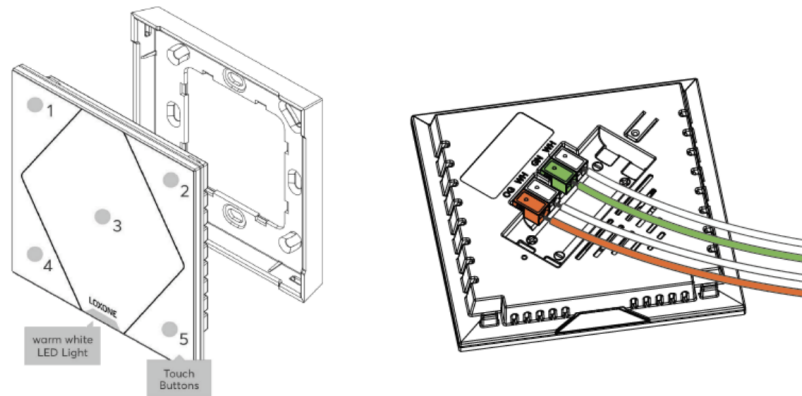

Product Characteristics

Colours	White: RAL 9003
---------	-----------------

Finish	Matte
--------	-------

Weight & Dimensions

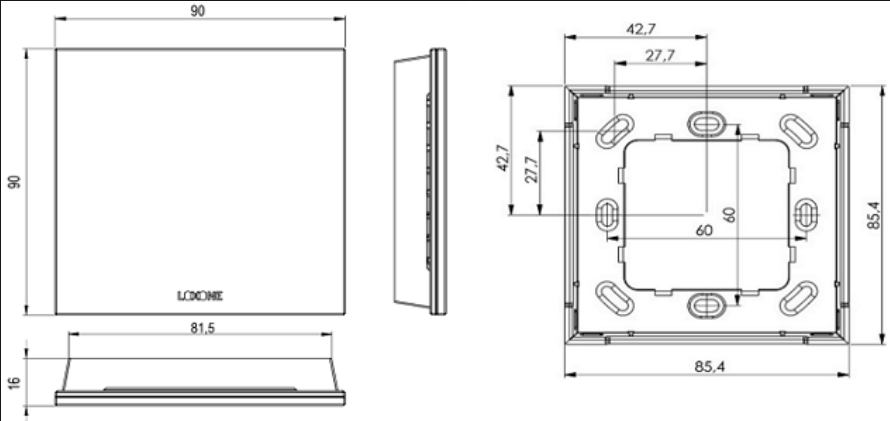
Net weight	110 g
Total weight	136 g
Product dimensions	90 x 90 x 16 mm / 3.55 x 3.55 x 0.63" (L x W x H)
Product dimensions drawing	 <p>The drawing consists of three views: a front view showing a square device with a width of 90 mm and a height of 16 mm; a side view showing a thickness of 16 mm; and a top view showing a square device with a width of 85.4 mm and a height of 85.4 mm. The top view also shows a central square area with a width of 60 mm and a height of 60 mm, and four mounting holes. The word 'LOXONE' is visible on the front view.</p>
Pack size	104 x 107 x 39 mm / 4.09 x 4.21 x 1.54" (L x W x H)

Certifications & Standards

Safety class	IP30
Certifications	 <p>The certifications shown are CE, UKCA, and ETL Intertek.</p>

Installation must be carried out by a qualified electrician in accordance with the relevant regulations.

Published by

Loxone Electronics GmbH
Smart Home 1
4154 Kollerschlag
Austria
Tel: +43 7287 7070-0
loxone.com

Loxone UK Ltd.
The Forum
Station Road
Theale, RG7 4RA
United Kingdom

Datenblatt

Touch Pure Classic

Tree Signalweiß

Part No: 100461



Über das Produkt

Der LOXONE Touch Pure Tree verfügt über **fünf Tastpunkte** auf einer Glasfront, zur Bedienung der wichtigsten Funktionen eines Raumes. Bei Berührung einer Taste erfolgt ein Klicken als **akustische Bestätigung**. Das integrierte Orientierungslicht hilft nicht nur, den Taster im Dunkeln zu finden – es sorgt auch nachts für dezente Beleuchtung und sichere Orientierung im Raum.

Features:

- Ein Bedienelement zur Steuerung von Beleuchtung, Beschattung, Audio und mehr
- Integrierter Temperatur- und Feuchtefühler zur Raumklimasteuerung
- Integriertes Orientierungslicht
- Hochwertige Haptik und Optik
- Einfache Installation dank LOXONE Tree Technologie

Für die beste Benutzererfahrung in Ihren Projekten empfehlen wir: Setze ab sofort auf [den neuen Touch Pure](#). Das überarbeitete Design bietet maximale Nutzerfreundlichkeit und passt perfekt zu modernen Interieurs.

Elektrische Spezifikationen

Versorgungsspannung	6 ... 30 VDC
Leistungsaufnahme	typ. 0,049 W, max. 0,095 W
Verlustleistung	max. 95mW
Temperatur	-20 ... 70°C / -4 ... 158°F
Tastpunkte	5 Tastpunkte, kapazitive Berührungserkennung
Messbereich Temperatursensor	-40 ... 125°C / -40 ... 257°F; +/- 0.5°C / 0.9°F
Messbereich Luftfeuchtigkeitssensor	0 ... 100% r.H. +/- 2%, (nicht kondensierend)
Orientierungslicht	Ja
Empfohlene Montagehöhe	135cm / 53,15"

Schnittstellen

LOXONE Tree | Verbindung mit Miniserver / Tree Extension

Umgebungsbedingungen

Luftfeuchtigkeit | max. 95% r.H. (nicht kondensierend)

Bedienelemente

Klick Feedback | Ja

Anschlussklemmen

Leiterquerschnitt | 0,25 ... 0,8 mm² / AWG 23 ... 18

Abisolierlänge | 5 mm / 0,2"

Temperaturbeständigkeit | -40 ... 105°C / -40 ... 221°F

Anschlussplan

Anschlussplan

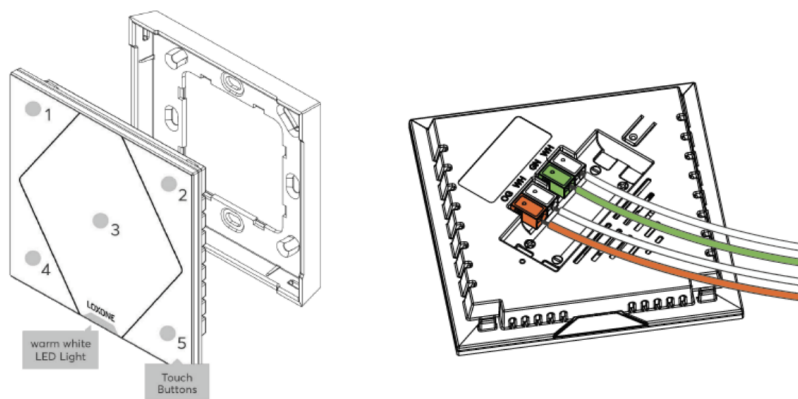

Produkteigenschaften

Farbe | Weiß: RAL 9003

Glanzgrad | Matt

Gewicht & Abmessungen

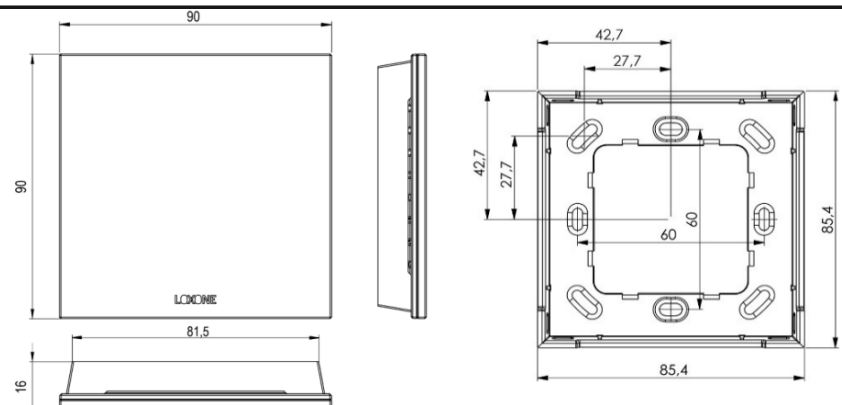
Nettogewicht	110 g
Bruttogewicht	136 g
Produktmaße	90 x 90 x 16 mm / 3,55 x 3,55 x 0,63" (L x B x H)
Produktmaßzeichnung	 <p>The technical drawing consists of three views: a front view, a side view, and a top view. The front view shows a square device with a width of 90 mm and a height of 90 mm. The bottom edge is slightly recessed, with a depth of 16 mm. The bottom edge is labeled 'LOXONE'. The side view shows the device's thickness of 16 mm. The top view shows a square with a side length of 85.4 mm. It features a central square with a side length of 60 mm. The distance from the center of the top edge to the center of the top hole is 42.7 mm. The distance from the center of the top edge to the center of the top hole is 27.7 mm. The distance from the center of the top edge to the center of the top hole is 27.7 mm. The distance from the center of the top edge to the center of the top hole is 27.7 mm.</p>
Packmaß	104 x 107 x 39 mm / 4,09 x 4,21 x 1,54" (L x B x H)

Zertifizierungen & Standards

Schutzklasse	IP30
Zertifizierungen	 <p>The certification logos are: CE, UKCA, and ETL Intertek.</p>

Die Installation muss von einer qualifizierten Elektrofachkraft gemäß den einschlägigen Vorschriften durchgeführt werden.

Veröffentlicht von

Loxone Electronics GmbH
Smart Home 1
4154 Kollerschlag
Austria
Tel: +43 7287 7070-0
loxone.com

Loxone UK Ltd.
The Forum
Station Road
Theale, RG7 4RA
United Kingdom