

Datasheet

Mounting Frame 2-Way Silver

Part No: 100489



About the product

The high-quality 2-mounting frame made of anodized aluminum is perfect for attaching the **Intercom**, the **NFC Code Touch (Gen. 2)**, the **Touch Pure** or the **Touch Pure Flex** to any facade.

Product Characteristics

| | |
|----------|--|
| Material | Aluminium |
| Colours | Silver: RAL9006 - Part No. 100489 Anthracite: RAL7021 - Part No. 100490 |

Weight & Dimensions

| | |
|--------------------|--|
| Net weight | 118 g |
| Net weight | 148 g |
| Product dimensions | 188x90x15.5mm / 7.4x3.55x0.63" (LxWxH) |
| Pack size | 204x107x39mm / 8.03x4.21x1.54" (LxWxH) |

Product dimensions drawing

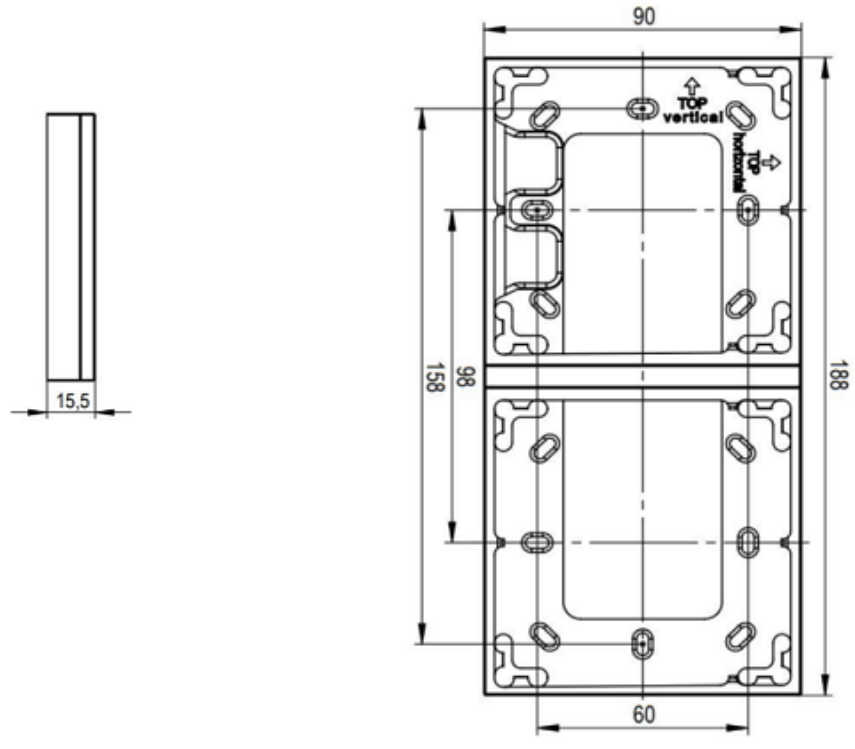

Installation must be carried out by a qualified electrician in accordance with the relevant regulations.

Published by

Loxone Electronics GmbH
Smart Home 1
4154 Kollerschlag
Austria
Tel: +43 7287 7070-0
loxone.com

Loxone UK Ltd.
The Forum
Station Road
Theale, RG7 4RA
United Kingdom

Datenblatt

Montagerahmen 2- fach Silber

Part No: 100489



Über das Produkt

Der hochwertige 2-Montagerahmen aus eloxiertem Aluminium eignet sich perfekt zur Befestigung der **Intercom**, des **NFC Code Touchs (Gen. 2)**, des **Touch Pures** oder des **Touch Pure Flex** auf jeder Fassade.

Produkteigenschaften

Material

Aluminium

Farbe

Silber: RAL9006 - Art. Nr. 100489

Anthrazit: RAL7021 - Art. Nr. 100490

Gewicht & Abmessungen

| | |
|--------------|--|
| Nettogewicht | 118 g |
| Nettogewicht | 148 g |
| Produktmaße | 188x90x15.5mm / 7,4x3,55x0,63" (LxBxH) |
| Packmaß | 204x107x39mm / 8,03x4,21x1,54" (LxBxH) |

Produktmaßzeichnung

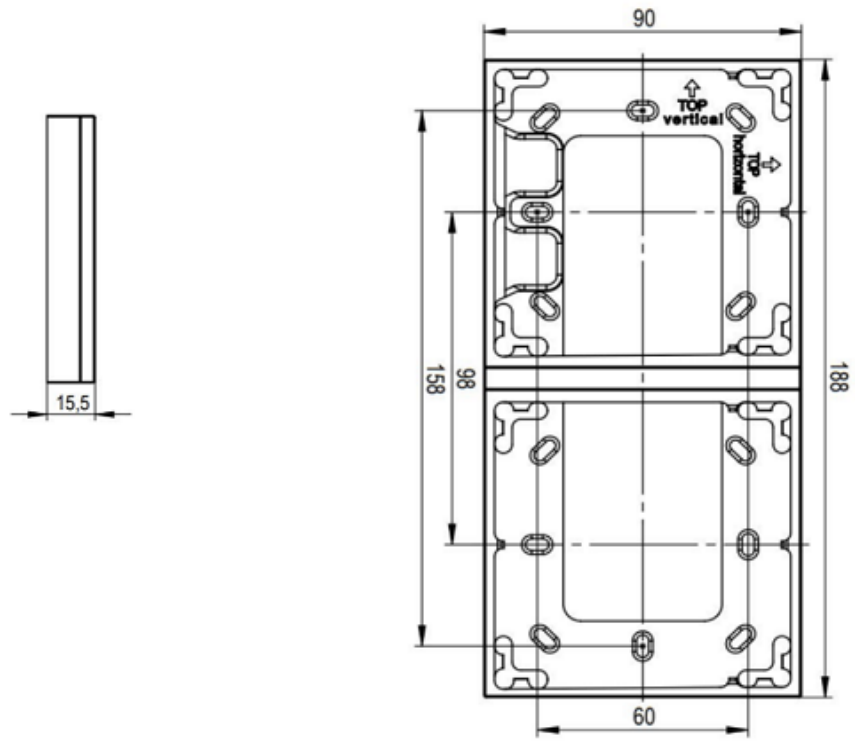

Die Installation muss von einer qualifizierten Elektrofachkraft gemäß den einschlägigen Vorschriften durchgeführt werden.

Veröffentlicht von

Loxone Electronics GmbH
Smart Home 1
4154 Kollerschlag
Austria
Tel: +43 7287 7070-0
loxone.com

Loxone UK Ltd.
The Forum
Station Road
Theale, RG7 4RA
United Kingdom