

Datasheet

Touch Pure Flex

Battery Air Anthracite

Part No: 100510



About the product

The Touch Pure Flex Air is your 100% personalized control device with up to **12 freely definable and positionable touch points**. Menus, values, texts and statuses can be displayed using the integrated **LED matrix display** and **3 status LEDs***. In addition, the Touch Pure Flex Air also serves as a room climate sensor thanks to the **integrated temperature and humidity sensor**.

Electrical Specifications

Power Supply	9 ... 28VDC or 2x AAA batteries
Power consumption	typ. 0.2W, max. 1.7W at display brightness 100%
Power loss	max. 1.7W
Battery Lifetime	up to 1 year
Touch area	capacitive touch detection 12/14 touch points
Temperature detection range	-40 ... 125°C / -40 ... 257°F; +/- 0.5°C / 0.9°F
Humidity detection range	0 ... 100% r.H. +/- 2%, (non condensing)
Recommended mounting height	135cm / 53.15"

Interfaces

LOXONE Air	868MHz (SRD Band Europe), 4 channels available max. Power 15.1mW e.r.p. 915MHz (ISM Band Region 2), 10 channels available max. Power 13.2mW internal antenna
------------	--

Operating Elements

Click feedback	Yes
----------------	-----

Ambient Conditions

Temperature	-20 ... 40 °C / -4 ... 104 °F
Humidity	max. 95 % RH (non-condensing)

Connection Terminals

Terminal type	DG220B
Wire cross-section	0.28 ... 0.8 mm ² / AWG 23 ... 18
Stripping length	5 ... 6 mm / 0.2 ... 0.24"
Temperature resistance	-40 ... 105°C / -40 ... 221°F

Connection Diagram

Connection Diagram

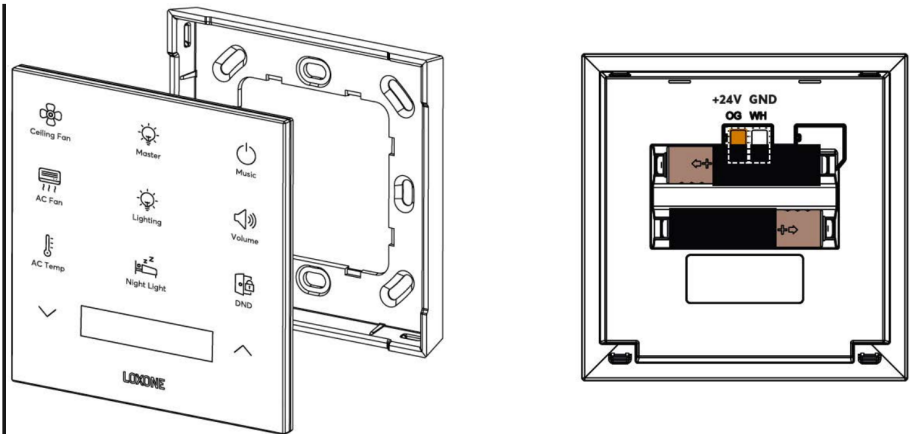

Product Characteristics

Colours	White: RAL9003 - Part No. 100509, 100540 Anthracite: RAL9005 - Part No. 100510, 100524, 100560
Finish	Matte

Weight & Dimensions

Net weight	102 g
Total weight	167 g
Product dimensions	90 x 90 x 16 mm / 3.55 x 3.55 x 0.63" (L x W x H)
Pack size	104 x 107 x 39 mm / 4.09 x 4.21 x 1.54" (L x W x H)

Certifications & Standards

Safety class

IP44

Certifications



Installation must be carried out by a qualified electrician in accordance with the relevant regulations.

Published by

Loxone Electronics GmbH
Smart Home 1
4154 Kollerschlag
Austria
Tel: +43 7287 7070-0
loxone.com

Loxone UK Ltd.
The Forum
Station Road
Theale, RG7 4RA
United Kingdom

Datenblatt

Touch Pure Flex

Battery Air Anthrazit

Part No: 100510



Über das Produkt

Der Touch Pure Flex Air ist mit bis zu **12 frei definier- und positionierbaren Touchpunkten** dein 100% personalisiertes Bediengerät. Mit dem integrierten **LED Matrix Display**, sowie **3 Status LEDs*** können Menüs, Werte, Texte und Stati ausgegeben werden. Zudem dient der Touch Pure Flex Air dank **integriertem Temperatur- und Feuchtesensor** zugleich als Raumklimasensor.

Elektrische Spezifikationen

Spannungsversorgung	9 ... 28VDC oder 2x AAA Batterien
Leistungsaufnahme	typ. 0,2W, max. 1,7W bei Display Helligkeit 100%
Verlustleistung	max. 1.7W
Batterie Lebensdauer	bis zu 1 Jahr
Tastbereich	kapazitive Berührungserkennung 12/14 Tastpunkte
Messbereich Temperatursensor	-40 ... 125°C / -40 ... 257°F; +/- 0.5°C / 0.9°F
Messbereich Luftfeuchtigkeitssensor	0 ... 100% r.H. +/- 2%, (nicht kondensierend)
Empfohlene Montagehöhe	135cm / 53,15"

Schnittstellen

LOXONE Air	868MHz (SRD Band Europa), 4 Kanäle wählbar max. Sendeleistung 15,1mW e.r.p. 915MHz (ISM Band Region 2), 10 Kanäle wählbar max. Sendeleistung 13,2mW interne Antenne
------------	---

Bedienelemente

Klick Feedback	Ja
----------------	----

Umgebungsbedingungen

Temperatur	-20 ... 40 °C / -4 ... 104 °F
Luftfeuchtigkeit	max. 95 % r. F. (nicht kondensierend)

Anschlussklemmen

Klemmentyp	DG220B
Leiterquerschnitt	0,28 ... 0,8 mm ² / AWG 23 ... 18
Abisolierlänge	5 ... 6 mm / 0,2 ... 0,24"
Temperaturbeständigkeit	-40 ... 105°C / -40 ... 221°F

Anschlussplan

Anschlussplan

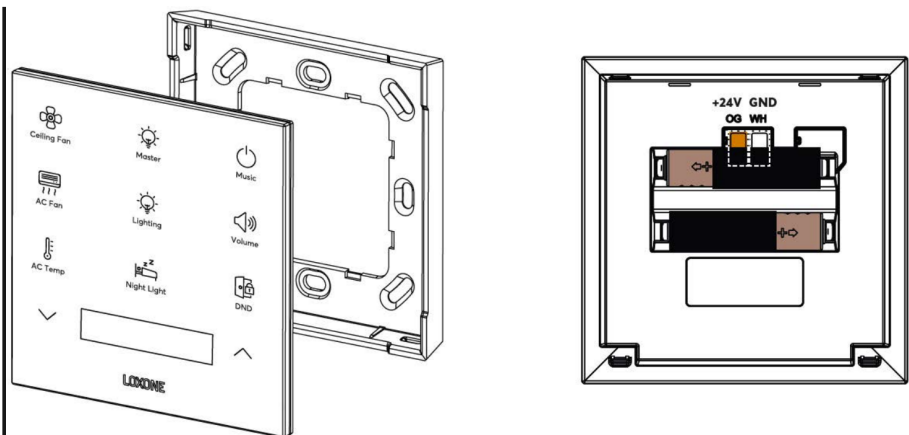

Produkteigenschaften

Farbe	Weiß: RAL9003 - Art. Nr. 100509, 100540 Anthrazit: RAL9005 - Art. Nr. 100510, 100524, 100560
Glanzgrad	Matt

Gewicht & Abmessungen

Nettogewicht	102 g
Bruttogewicht	167 g
Produktmaße	90 x 90 x 16 mm / 3,55 x 3,55 x 0,63" (L x B x H)
Packmaß	104 x 107 x 39 mm / 4,09 x 4,21 x 1,54" (L x B x H)

Zertifizierungen & Standards

Schutzklasse

IP44

Zertifizierungen



Die Installation muss von einer qualifizierten Elektrofachkraft gemäß den einschlägigen Vorschriften durchgeführt werden.

Veröffentlicht von

Loxone Electronics GmbH
Smart Home 1
4154 Kollerschlag
Austria
Tel: +43 7287 7070-0
loxone.com

Loxone UK Ltd.
The Forum
Station Road
Theale, RG7 4RA
United Kingdom