

Datasheet

Touch Pure Classic

CO2 Tree Anthracite

Part No: 100518



About the product

The LOXONE Touch Pure CO2 Tree has **five touch points** on a glass front for operating the most important functions in a room. When a button is touched, a click is heard as **acoustic confirmation**. A sensor is integrated to measure **temperature, relative humidity and CO2 levels**. An **orientation light** enables the device to be recognized in the dark.

For the best user experience in your projects, we recommend: Switch to [the new Touch Pure](#) now. The revised design offers maximum user-friendliness and fits perfectly into modern interiors.

Electrical Specifications

Supply voltage	9 ... 30 V DC
Power consumption	typ. 0.05 W, max. 0.1 W
Power loss	max. 0.1 W
LOXONE Tree	LOXONE Tree: connection with Miniserver / Tree Extension
Touch points	5 touch points, capacitive touch detection
Orientation light	Yes
Temperature detection range	-40 ... 125°C / -40 ... 257°F; +/- 0.5°C / 0.9°F
Humidity detection range	0 ... 100% r.H. +/- 2%, (non condensing)
CO2 detection range	0 ... 40.000ppm
Temperature	-20 ... 70°C / -4 ... 158°F
Recommended mounting height	135cm / 53.15"

Operating Elements

Click feedback	Yes
----------------	-----

Functional Specifications

Calibrated CO2 detection range	400 ... 2 000 ppm (± 50 ppm, + 5 % of reading) NDIR Sensor
--------------------------------	--

Ambient Conditions

Humidity	max. 95 % RH (non-condensing)
Temperature	-20 ... 70 °C / -4 ... 158 °F

Connection Terminals

Terminal type	DG220B
---------------	--------

Connections

Wire cross-section	0.28 ... 0.8mm ² / AWG23 ... 18
Stripping length	5 ... 6mm / 0.2 ... 0.24"
Temperature resistance	-40 ... 105°C / -40 ... 221°F

Connection Diagram

Connection Diagram

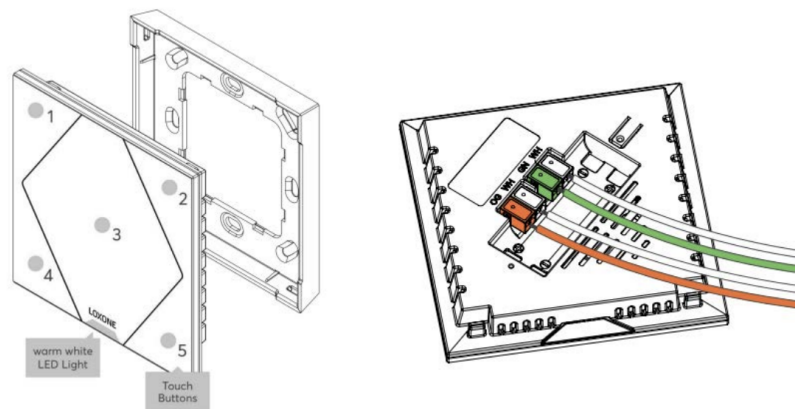

Product Characteristics

Colours	White: RAL9003 - Part No. 100517 Anthracite: RAL7021 - Part No. 100518
Finish	Matte

Weight & Dimensions

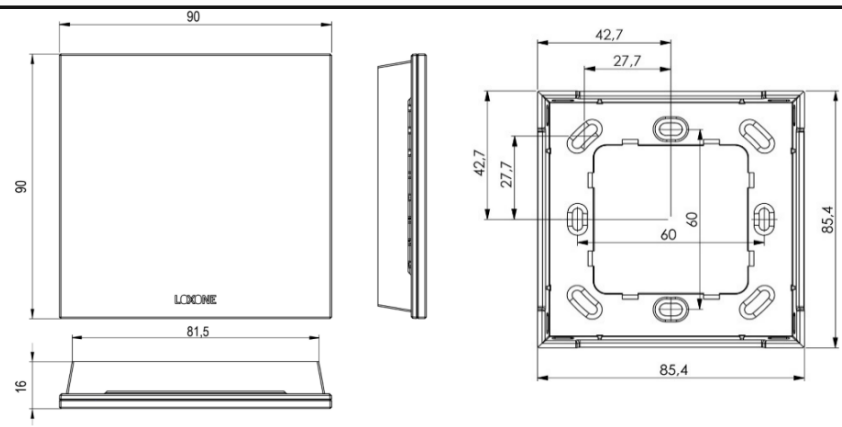
Net weight	110 g
Total weight	136 g
Product dimensions	90 x 90 x 16 mm / 3.55 x 3.55 x 0.63" (L x W x H)
Product dimensions drawing	 <p>The drawing consists of three views: a front view showing a square face with a width of 90 mm and a height of 90 mm, with a depth of 16 mm; a side view showing the profile of the device; and a top view showing the internal layout with dimensions of 85.4 mm by 85.4 mm, and internal clearances of 42.7 mm, 27.7 mm, and 60 mm. The brand name 'LOXONE' is visible on the front view.</p>
Pack size	104 x 107 x 39 mm / 4.09 x 4.21 x 1.54" (L x W x H)

Certifications & Standards

Safety class	IP30
Certifications	

Installation must be carried out by a qualified electrician in accordance with the relevant regulations.

Published by

Loxone Electronics GmbH
Smart Home 1
4154 Kollerschlag
Austria
Tel: +43 7287 7070-0
loxone.com

Loxone UK Ltd.
The Forum
Station Road
Theale, RG7 4RA
United Kingdom

Datenblatt

Touch Pure Classic CO2 Tree Anthrazit

Part No: 100518



Über das Produkt

Der LOXONE Touch Pure CO2 Tree verfügt über **fünf Tastpunkte** auf einer Glasfront, zur Bedienung der wichtigsten Funktionen eines Raumes. Bei Berührung einer Taste erfolgt ein Klicken als **akustische Bestätigung**. Zur Messung von **Temperatur, relativer Luftfeuchte und CO2 Wert** ist ein Sensor integriert. Ein **Orientierungslicht** ermöglicht das Erkennen des Gerätes im Dunkeln.

Für die beste Benutzererfahrung in Ihren Projekten empfehlen wir: Setze ab sofort auf [den neuen Touch Pure CO2](#). Das überarbeitete Design bietet maximale Nutzerfreundlichkeit und passt perfekt zu modernen Interieurs.

Elektrische Spezifikationen

Versorgungsspannung	9 ... 30 V DC
Leistungsaufnahme	typ. 0,05 W, max. 0,1W
Verlustleistung	max. 0,1 W
LOXONE Tree	LOXONE Tree: Verbindung mit Miniserver / Tree Extension
Tastpunkte	5 Tastpunkte, kapazitive Berührungserkennung
Orientierungslicht	Ja
Messbereich Temperatursensor	-40 ... 125°C / -40 ... 257°F; +/- 0.5°C / 0.9°F
Messbereich Luftfeuchtigkeitssensor	0 ... 100% r.H. +/- 2%, (nicht kondensierend)
CO2 Erfassungsbereich	0 ... 40.000ppm
Temperatur	-20 ... 70°C / -4 ... 158°F
Empfohlene Montagehöhe	135cm / 53,15"

Bedienelemente

Klick Feedback | Ja

Funktionale Spezifikationen

Kalibrierter CO2 Messbereich | 400 ... 2 000 ppm (± 50 ppm, + 5 % des Messwerts)
NDIR Sensor

Umgebungsbedingungen

Luftfeuchtigkeit | max. 95 % r. F. (nicht kondensierend)

Temperatur | -20 ... 70 °C / -4 ... 158 °F

Anschlussklemmen

Klemmentyp | DG220B

Anschlüsse

Leiterquerschnitt | 0,28 ... 0,8mm² / AWG23 ... 18

Abisolierlänge | 5 ... 6mm / 0,2 ... 0,24"

Temperaturbeständigkeit | -40 ... 105°C / -40 ... 221°F

Anschlussplan

Anschlussplan

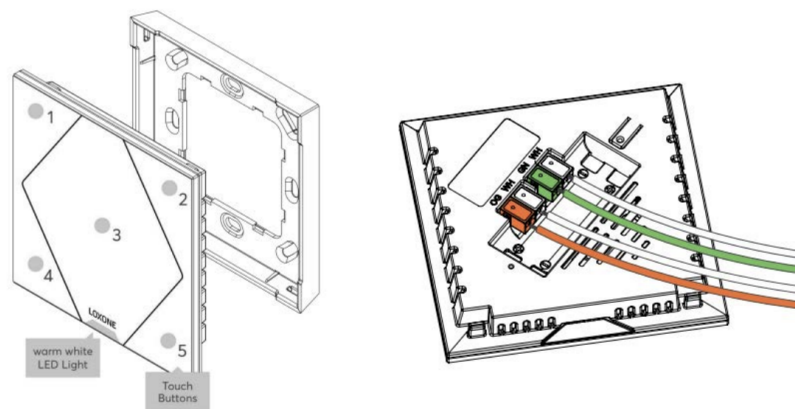

Produkteigenschaften

Farbe | Weiß: RAL9003 - Part No. 100517
Anthrazit: RAL7021 - Part No. 100518

Glanzgrad | Matt

Gewicht & Abmessungen

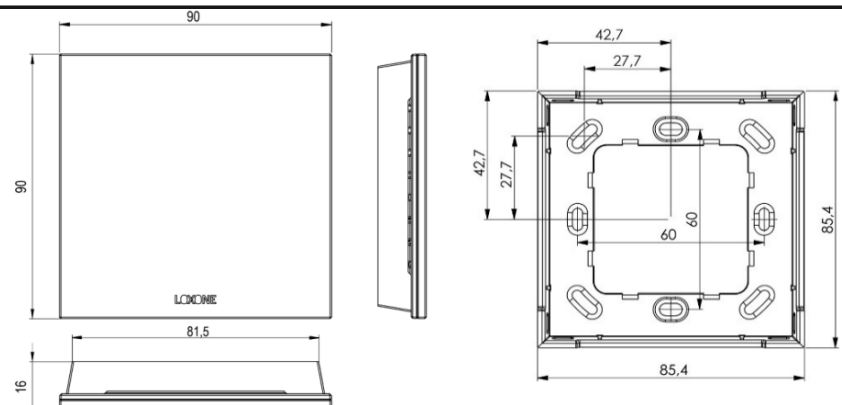
Nettogewicht	110 g
Bruttogewicht	136 g
Produktmaße	90 x 90 x 16 mm / 3,55 x 3,55 x 0,63" (L x B x H)
Produktmaßzeichnung	
Packmaß	104 x 107 x 39 mm / 4,09 x 4,21 x 1,54" (L x B x H)

Zertifizierungen & Standards

Schutzklasse	IP30
Zertifizierungen	 

Die Installation muss von einer qualifizierten Elektrofachkraft gemäß den einschlägigen Vorschriften durchgeführt werden.

Veröffentlicht von

Loxone Electronics GmbH
Smart Home 1
4154 Kollerschlag
Austria
Tel: +43 7287 7070-0
loxone.com

Loxone UK Ltd.
The Forum
Station Road
Theale, RG7 4RA
United Kingdom