

Datasheet

Belimo Tree

Part No: 100519



About the product

Belimo is one of the **leading manufacturers** of drives in the field of heating, ventilation and air conditioning technology. Belimo Tree is an interface for the **integration** of up to **16 Belimo MP-Bus devices** and is used to optimize flap drives, integrate sensors and meters, configure valves and much more. With the **native MP-Bus integration**, Belimo products become a native member of Loxone Config and the Miniserver.

Electrical Specifications

Supply voltage	19.3 ... 30 VDC
Power consumption	typ. 0.33 W
Loxone Tree	connection with Miniserver / Tree Extension
Power loss at max. load	0.34 W
Ambient temperature - line powered	-20 ... 70°C / -4 ... 158°F

Interfaces

Belimo MP-Bus	MPL devices exclusive: up to 16 MP-Bus devices mixed: up to 8
---------------	--

Ambient Conditions

Humidity	max. 95% r.H. (non condensing)
----------	--------------------------------

Connection Terminals

Terminal type	DC Supply, Loxone Tree: DG220B MP-Bus: Connecting lead with open end
Wire cross-section	DC Supply, Loxone Tree: 0.28 ... 0.8mm ² AWG23 ... 18 MP-Bus: 1.5mm ² / AWG18
Stripping length	DC Supply, Loxone Tree: 5 ... 6mm 0.2 ... 0.24" MP-Bus: -
Length	DC Supply, Loxone Tree: MP-Bus: 150mm / 5.91"
Temperature resistance	DC Supply, Loxone Tree: -40 ... 105°C / -40 ... 221°F MP-Bus: min. 80°C / 176°F IEC, min. 75°C / 167°F UL

Connection Diagram

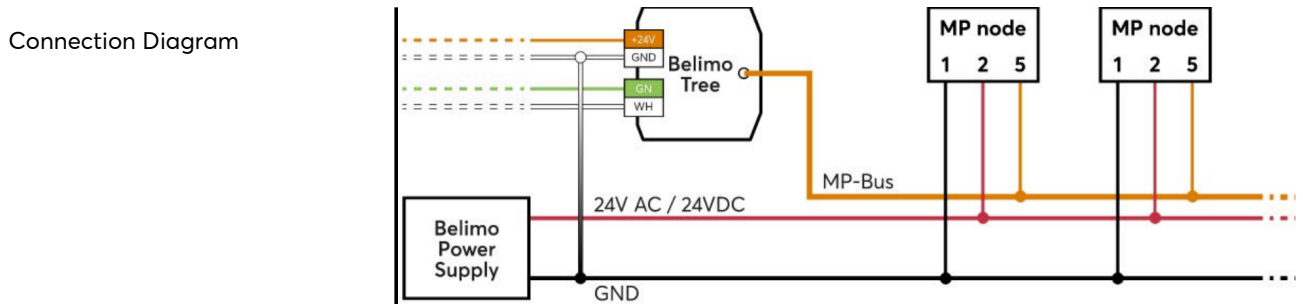

Product Characteristics

Colours	Green: RAL 6018
Finish	Matte

Weight & Dimensions

Net weight	37g
Total weight	59g
Product dimensions	39.45x38.95x20.20mm / 1.55x1.53x0.80" (LxWxH)
Product dimensions drawing	
Pack size	84x80x47mm / 3.31x3.15x1.85" (LxWxH)

Certifications & Standards

Safety class

IP20

Certifications



Installation must be carried out by a qualified electrician in accordance with the relevant regulations.

Published by

Loxone Electronics GmbH
Smart Home 1
4154 Kollerschlag
Austria
Tel: +43 7287 7070-0
loxone.com

Loxone UK Ltd.
The Forum
Station Road
Theale, RG7 4RA
United Kingdom

Datenblatt

Belimo Tree

Part No: 100519



Über das Produkt

Belimo ist einer der **führenden Hersteller** von Antrieben im Bereich der Heizungs-, Lüftungs- und Klimatechnik. Belimo Tree ist eine Schnittstelle zur **Integration** von bis zu **16 Belimo MP-Bus Geräten** und **dient der Optimierung** von Klappantrieben, der Einbindung von Sensoren und Zählern, der Konfiguration von Ventilen und vielem mehr. Mit der **nativen MP-Bus-Integration** werden Belimo-Produkte einfach in die Haus- und Gebäudeautomation von Loxone eingebunden.

Elektrische Spezifikationen

Versorgungsspannung	19,3 ... 30 VDC
Leistungsaufnahme	typ. 0,33 W
Loxone Tree	Verbindung mit Miniserver / Tree Extension
Verlustleistung bei max. Last	0,34 W
Umgebungstemperatur - spannungsversorgt	-20 ... 70°C / -4 ... 158°F

Schnittstellen

Belimo MP-Bus	Ausschließlich MPL Geräte: bis zu 16 MP-Bus Geräte gemischt: bis zu 8
---------------	--

Umgebungsbedingungen

Luftfeuchtigkeit	max. 95% r.H. (nicht kondensierend)
------------------	-------------------------------------

Anschlussklemmen

Klemmentyp	DC Versorgung, Loxone Tree: DG220B MP-Bus: Anschlussleitung mit offenem Ende
Leiterquerschnitt	DC Versorgung, Loxone Tree: 0,28 ... 0,8mm ² AWG23 ... 18 MP-Bus: 1,5mm ² / AWG18
Abisolierlänge	DC Versorgung, Loxone Tree: 5 ... 6mm 0,2 ... 0,24" MP-Bus: -
Länge	DC Versorgung, Loxone Tree: MP-Bus: 150mm / 5,91"
Temperaturbeständigkeit	DC Versorgung, Loxone Tree: -40 ... 105°C / -40 ... 221°F MP-Bus: min. 80°C / 176°F IEC, min. 75°C / 167°F UL

Anschlussplan

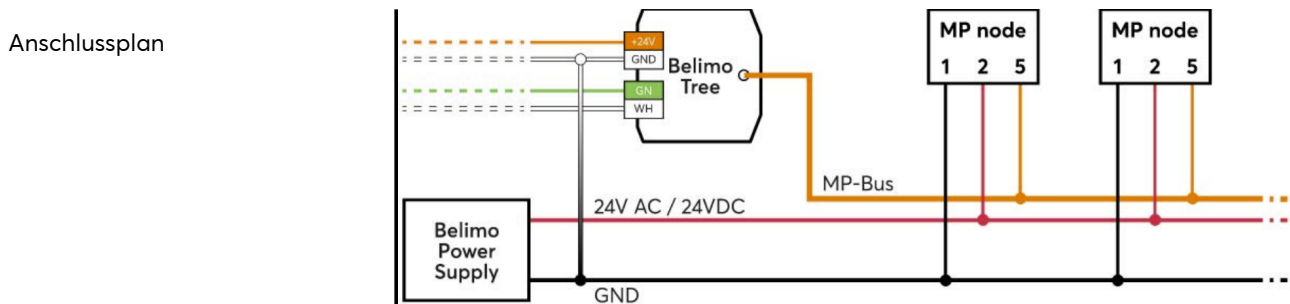

Produkteigenschaften

Farbe	Grün: RAL 6018
Glanzgrad	Matt

Gewicht & Abmessungen

Nettogewicht	37g
Bruttogewicht	59g
Produktmaße	39,45x38,95x20,20mm / 1,55x1,53x0,80" (LxBxH)
Produktmaßzeichnung	<p>Technical drawing showing three views of the terminal block. The front view shows the terminal block with labels: HM, GN, WH, HM, GN, WH. The side view shows the depth of 20,20mm. The top view shows the width of 39,45mm. The height is 38,95mm.</p>
Packmaß	84x80x47mm / 3,31x3,15x1,85" (LxBxH)

Zertifizierungen & Standards

Schutzklasse

IP20

Zertifizierungen



Die Installation muss von einer qualifizierten Elektrofachkraft gemäß den einschlägigen Vorschriften durchgeführt werden.

Veröffentlicht von

Loxone Electronics GmbH
Smart Home 1
4154 Kollerschlag
Austria
Tel: +43 7287 7070-0
loxone.com

Loxone UK Ltd.
The Forum
Station Road
Theale, RG7 4RA
United Kingdom