

## Datasheet

### Wallbox 11kW 16A Tree

Part No: 100526



#### About the product

The LOXONE **Wallbox** enables dynamic charging from **1.38kW to 11kW** for electric vehicles. The **Tree interface** allows all the freedom for efficient **energy management**.

#### Features:

- Charge for free: use PV surplus efficiently
- Electricity exchange included: charge cheaply, even without a PV system. Ideal for variable electricity tariffs
- Easy operation with the Touch Pure Flex or the LOXONE app
- Fleet-compatible: Protection of the line and the building thanks to optimal power distribution
- User identification and billing via NFC
- Optional expansion with touch devices, meters
- Up to 5 customizable charging modes
- Easy integration via Tree
- OCPP capable
- MID compliance achievable in combination with the LOXONE [Energy Meter Tree](#)
- Certified for TOR in accordance with OVE R37:2024

#### Supply and Power

Rated voltage	<b>AC Input (mains)</b>	<b>24 VDC Input</b>
	3 x 230/400 V or 1x 230 V, 50-60 Hz	18-24 V
Rated current	AC Input (mains): 3x 16A or 1x 16A 24V DC Input: max. 400mA	
Power consumption	AC Input (mains): - 24V DC Input: Standby: 0.3W charging: 3W A 30mA type A RCD must be connected before each wallbox!	

## Charging

Max. charging power	11kW (3 phase 16A) 3.7kW (1 phase 16A) configurable from 1.38kW to 3.7/11kW
Charging Mode	Charging mode 3 (IEC 61851-1)
Residual current detection	Internal, RDC-MD, DC 6 mA, (IEC 62955)
Charging cable with plug	Type 2 plug (IEC 62196) 5 meter cable, 5 x 4 mm <sup>2</sup> + 1 x 0.5 mm <sup>2</sup>

## Interfaces

LOXONE Tree	Connection with Miniserver / Tree Extension
Modbus RTU	max. 1 device max. 3 m wire length adjustable baud rate & parity data types: 16 & 32 bit min. polling cycle: 0.1 s / 1 s
OCPP	1.6 & 2.0.1, NFC Code Touch required

## Ambient Conditions

Temperature	-20 ... 50 °C / -4 ... 122 °F
Humidity	max. 95 % RH (non-condensing)
Ingress protection	IP44 (IEC 60529) IK08 (IEC 62262)
Appliance class	Class I
Installation	Stationary, surface mount, vertical on wall or charging post
Recommended mounting height	Cable outlet: 132cm / 52" Top edge: 165cm / 65"
Altitude	max. 2000 m

## Connection Terminals

Terminal type	AC Input, Charging Output	DC Input	LOXONE Tree	Modbus
	DG2206V	PT 1.5	DG220B	SPTAF 1
Wire cross-section	0.5 ... 6 mm <sup>2</sup> / AWG 20 ... 8	0.75 ... 2.5 mm <sup>2</sup> / AWG 18 ... 13	0.28 ... 0.8 mm <sup>2</sup> / AWG 23 ... 18	0.25 ... 0.75 mm <sup>2</sup> / AWG 24 ... 16
Stripping length	12 mm / 0.47"	5 mm / 0.2"	5 ... 6 mm / 0.2 ... 0.24"	8 mm / 0.31"
Temperature resistance	-40 ... 105 °C / - 40 ... 221 °F	-40 ... 105 °C / - 40 ... 221 °F	-40 ... 105 °C / - 40 ... 221 °F	-60 ... 100 °C / - 76 ... 212 °F
Tightening torque	-	0.35 ... 0.4 Nm / 0.26 ... 0.3 lbf·ft	-	-
Terminal compartment	DIN Rail with 158mm / 6.2" width, room for devices with up to 9 division/breaker units			

## Connection Diagram

Connection Diagram

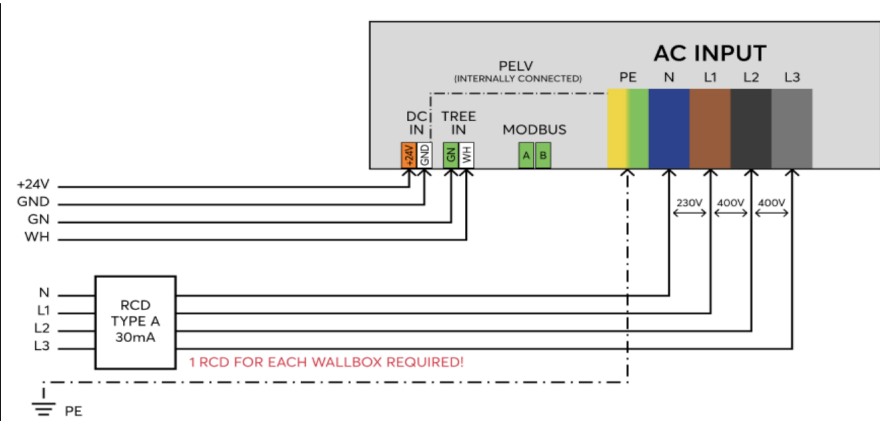

## Product Characteristics

Colours

Housing: RAL 9005  
Decor cover: RAL 9003



Finish

Matte

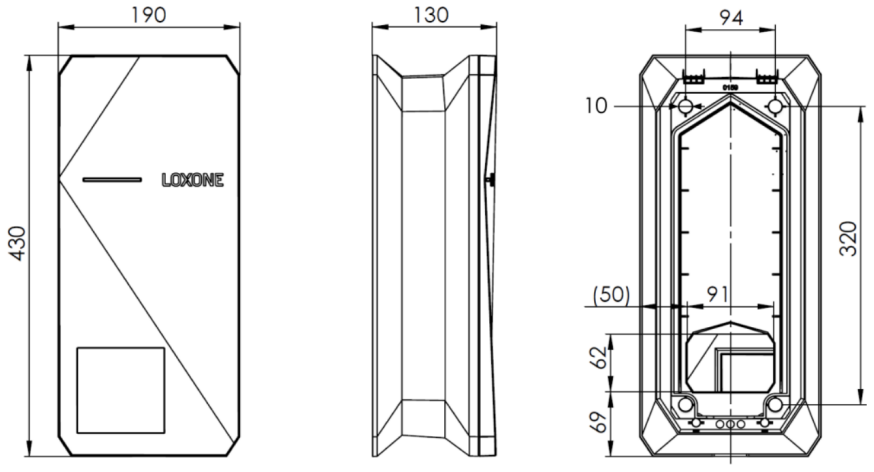
## Weight & Dimensions

Net weight	3.5 kg
Total weight	4.8 kg
Product dimensions	430x190x130mm / 16.93x7.48x5.12" (HxWxD)
Product dimensions drawing	
Pack size	575x330x155mm / 22.64x12.99x6.1" (HxWxD)

## Certifications & Standards

Degree of pollution	3
Standards	CE (LVD 2014/35/EU, EMC 2014/0/EU) IEC 61851-1 IEC 61851-22
Certifications	Compatible with ChargePoint be.ENERGISED (OCPP 1.6) OVE R37:2024 (AT TOR)
Certifications	 

Installation must be carried out by a qualified electrician in accordance with the relevant regulations.

### Published by

Loxone Electronics GmbH  
Smart Home 1  
4154 Kollerschlag  
Austria  
Tel: +43 7287 7070-0  
loxone.com

Loxone UK Ltd.  
The Forum  
Station Road  
Theale, RG7 4RA  
United Kingdom

# Datenblatt

## Wallbox 11kW 16A Tree

Part No: 100526



### Über das Produkt

Die LOXONE **Wallbox** ermöglicht dynamisches Laden von **1,38kW bis 11kW** für Elektrofahrzeuge. Die **Tree Schnittstelle** ermöglicht alle Freiheiten für ein effizientes **Energiemanagement**.

#### Features:

- Kostenlos laden: PV-Überschuss effizient nutzen
- Strombörse inklusive: Günstig laden, auch ohne PV-Anlage. Ideal für variable Stromtarife
- Einfache Bedienung mit dem Touch Pure Flex oder der LOXONE App
- Flottentauglich: Absicherung der Leitung und des Gebäudes dank optimaler Leistungsverteilung
- Nutzeridentifikation und Abrechnung per NFC
- Optionale Erweiterung durch Touch Geräte, Zähler
- Bis zu 5 anpassbare Lademodi
- Einfache Integration über Tree
- OCPP fähig
- MID-Konformität erreichbar in Kombination mit LOXONE [Energiezähler Tree](#)
- Zertifiziert für TOR nach OVE R37:2024

### Versorgung und Leistung

Nennspannung	AC-Eingang (Netzspannung)	24 VDC Eingang
	3 x 230/400 V or 1x 230 V, 50-60 Hz	18-24 V
Nennstrom	AC Eingang (Netzspannung): 3x 16A or 1x 16A 24V DC Eingang: max. 400mA	
Leistungsaufnahme	AC Eingang (Netzspannung): - 24V DC Eingang: Standby: 0.3W charging: 3W Jeder Wallbox muss ein 30mA Typ A Fehlerstrom-Schutzschalter (RCD) vorgeschaltet werden.	

## Laden

Max. Ladeleistung	11kW (3 phasig 16A) 3,7kW (1 phasig 16A) einstellbar von 1,38kW bis 3,7/11kW
Ladebetriebsart	Ladebetriebsart 3 (IEC 61851-1)
Fehlerstromerkennung	Intern, RDC-MD, DC 6 mA, (IEC 62955)
Ladekabel mit Stecker	Typ 2 Stecker (IEC 62196) 5 Meter Kabel, 5 x 4 mm <sup>2</sup> + 1 x 0,5 mm <sup>2</sup>

## Schnittstellen

LOXONE Tree	Verbindung mit Miniserver / Tree Extension
Modbus RTU	max. 1 Gerät max. 3 m Leitungslänge einstellbare Baudrate & Parität Datentypen: 16 & 32 bit min. Abfragezyklus: 0,1s / 1s
OCPP	1.6 & 2.0.1, NFC Code Touch erforderlich

## Umgebungsbedingungen

Temperatur	-20 ... 50 °C / -4 ... 122 °F
Luftfeuchtigkeit	max. 95 % r. F. (nicht kondensierend)
Schutzart	IP44 (IEC 60529) IK08 (IEC 62262)
Schutzklasse	Klasse I
Installation	Ortsfest, Aufbaumontage, vertikal an Wand oder Ladesäule
Empfohlene Montagehöhe	Kabelausschuss: 132cm / 52" Oberkante: 165cm / 65"
Betriebshöhe	max. 2000 m

## Anschlussklemmen

Klemmentyp	AC Eingang, Ladeausgang	DC Eingang	LOXONE Tree	Modbus
	DG2206V	PT 1,5	DG220B	SPTAF 1
Leiterquerschnitt	0,5 ... 6 mm <sup>2</sup> / AWG 20 ... 8	0,75 ... 2,5 mm <sup>2</sup> / AWG 18 ... 13	0,28 ... 0,8 mm <sup>2</sup> / AWG 23 ... 18	0,25 ... 0,75 mm <sup>2</sup> / AWG 24 ... 16
Abisolierlänge	12 mm / 0,47"	5 mm / 0,2"	5 ... 6 mm / 0,2 ... 0,24"	8 mm / 0,31"
Temperaturbeständigkeit	-40 ... 105 °C / - 40 ... 221 °F	-40 ... 105 °C / - 40 ... 221 °F	-40 ... 105 °C / - 40 ... 221 °F	-60 ... 100 °C / - 76 ... 212 °F
Anzugsdrehmoment	-	0,35 ... 0,4 Nm / 0,26 ... 0,3 lbf·ft	-	-
Anschlussraum	Hutschiene mit 158mm / 6,2" Breite, Platz für Geräte mit bis zu 9 Teilungseinheiten			

## Anschlussplan

### Anschlussplan

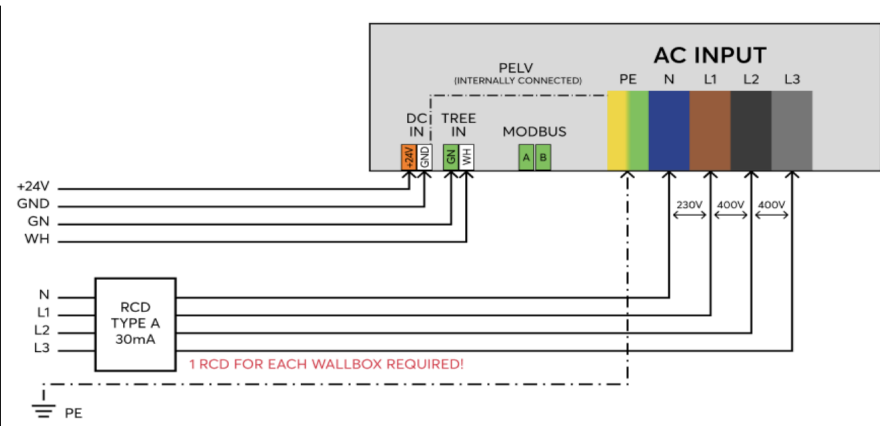



## Produkteigenschaften

Farbe	Gehäuse: RAL 9005 Dekorabdeckung: RAL 9003
Glanzgrad	Matt

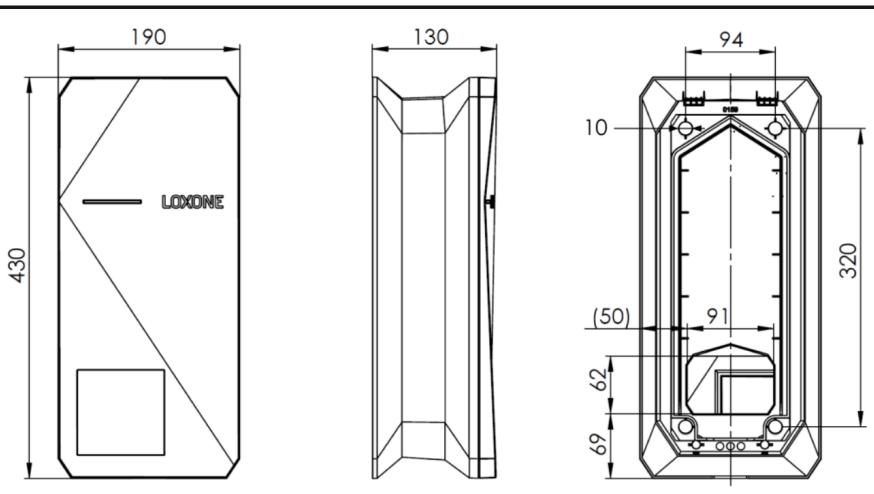
## Gewicht & Abmessungen

Nettogewicht	3,5 kg
Bruttogewicht	4,8 kg
Produktmaße	430x190x130mm / 16,93x7,48x5,12" (HxBxT)
Produktmaßzeichnung	
Packmaß	575x330x155mm / 22,64x12,99x6,1" (HxBxT)

## Zertifizierungen & Standards

Verschmutzungsgrad	3
Normen	CE (LVD 2014/35/EU, EMC 2014/0/EU) IEC 61851-1 IEC 61851-22
Zertifizierungen	Kompatibel mit ChargePoint be.ENERGISED (OCPP 1.6) OVE R37:2024 (AT TOR)
Zertifizierungen	 

Die Installation muss von einer qualifizierten Elektrofachkraft gemäß den einschlägigen Vorschriften durchgeführt werden.

### Veröffentlicht von

Loxone Electronics GmbH  
Smart Home 1  
4154 Kollerschlag  
Austria  
Tel: +43 7287 7070-0  
loxone.com

Loxone UK Ltd.  
The Forum  
Station Road  
Theale, RG7 4RA  
United Kingdom