

## Datasheet

### AC Control Air for Toshiba

Part No: 100554



#### About the product

With the AC Control Air for Toshiba, you can integrate Toshiba air conditioning systems **easily, quickly and seamlessly** into your LOXONE installation. The intelligent control of the air conditioning units can significantly increase comfort and at the same time reduce energy consumption **by more than 30%**.

#### Features:

- Simple, intuitive operation using LOXONE controls or the LOXONE app
- Heating & cooling according to needs in combination with presence detection, window status, shading and weather forecast
- Cost-effective heating & cooling thanks to integration into the energy management system (e.g. use of PV surplus)
- Optimal coordination of the air conditioning unit with other heating & Cooling sources for maximum energy efficiency
- Simplified integration of the grid-friendly control
- Invisible plug & play installation within the air conditioning system
- Analyze and optimize with individual status messages, statistics and notifications

#### Electrical Specifications

Power Supply	via AC unit (+5 VDC, 4.8 ... 5.1 VDC)
Power consumption	typ. 0.15 W, max. 0.2 W
LOXONE Air	868MHz (SRD Band Europe), 4 channels, max. 15.1mW e.r.p. 915MHz (ISM Band Region 2), 10 channels, max. 13.2mW internal antenna

#### Ambient Conditions

Temperature	-20 ... 65°C / -4 ... 149°F
Humidity	max. 95% r.H. (non condensing)

## Connecting Cable

Wire cross-section	0.14 mm <sup>2</sup> / AWG 26
Temperature resistance	80 °C / 176 °F
Length	300 mm / 11.81"
Part. No.	000587

## Connection Diagram

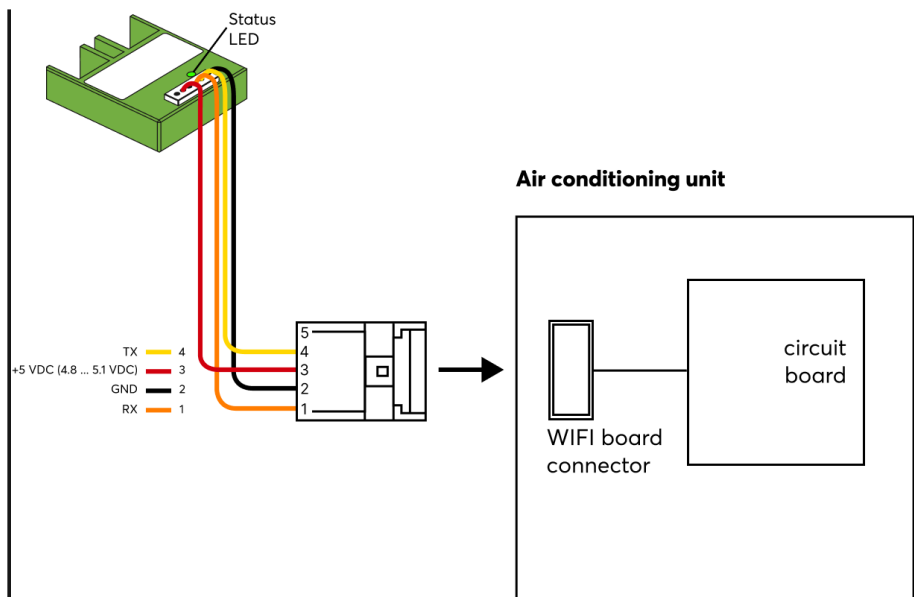

Connection Diagram



## Product Characteristics

Colours	Green: RAL 6018
Finish	Matte

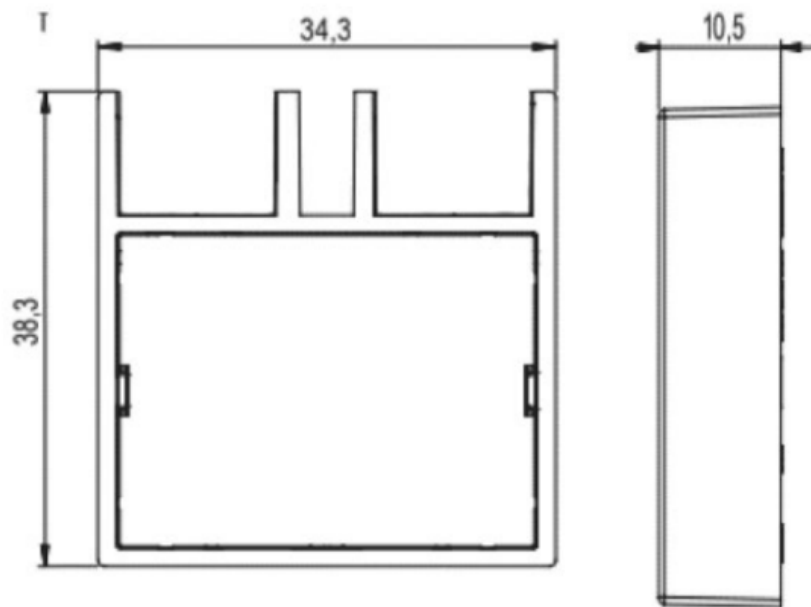
## Weight & Dimensions

Net weight	54 g
Total weight	74 g
Product dimensions	38.3 x 34.3 x 10.5 mm / 1.50 x 1.35 x 0.41" (L x W x H)
Product dimensions drawing	
Pack size	79 x 79 x 41 mm / 3.11 x 3.11 x 1.61" (L x W x H)
<b>Certifications &amp; Standards</b>	
Safety class	IP20
Certifications	 

Installation must be carried out by a qualified electrician in accordance with the relevant regulations.

### Published by

Loxone Electronics GmbH  
Smart Home 1  
4154 Kollerschlag  
Austria  
Tel: +43 7287 7070-0  
loxone.com

Loxone UK Ltd.  
The Forum  
Station Road  
Theale, RG7 4RA  
United Kingdom

# Datenblatt

## AC Control Air for Toshiba

Part No: 100554



### Über das Produkt

Mit dem AC Control Air für Toshiba bindest du Toshiba Klimaanlage **einfach, schnell und nahtlos** in deine LOXONE Installation ein. Durch die intelligente Ansteuerung der Klimageräte lässt sich der **Komfort deutlich erhöhen** und der **Energieverbrauch gleichzeitig um mehr als 30% senken**.

#### Features:

- Einfache, intuitive Bedienung mithilfe LOXONE Bedienelementen oder mit der LOXONE App
- Bedarfsgerechtes Heizen & Kühlen in Kombination mit Präsenzerkennung, Fensterstatus, Beschattung und Wettervorhersage
- Kostengünstiges Heizen & Kühlen dank Einbindung in das Energiemanagementsystem (z.B.: PV-Überschuss nutzen)
- Optimale Abstimmung des Klimageräts auf andere Heiz- & Kühlquellen für maximale Energieeffizienz
- Erleichterte Integration der netzdienlichen Steuerung
- Unsichtbare Plug & Play-Montage innerhalb der Klimaanlage
- Analysieren und Optimieren mit individuellen Statusmeldungen, Statistiken und Benachrichtigungen

### Elektrische Spezifikationen

Spannungsversorgung	von Klimaanlage (+5 VDC, 4,8 ... 5,1VDC)
Leistungsaufnahme	typ. 0,15 W, max. 0,2 W
LOXONE Air	868MHz (SRD Band Europa), 4 Kanäle, max. 15.1mW e.r.p. 915MHz (ISM Band Region 2), 10 Kanäle, max. 13.2mW interne Antenne

### Umgebungsbedingungen

Temperatur	-20 ... 65°C / -4 ... 149°F
Luftfeuchtigkeit	max. 95% r.H. (nicht kondensierend)

## Verbindungskabel

Leiterquerschnitt	0.14 mm <sup>2</sup> / AWG 26
Temperaturbeständigkeit	80 °C / 176 °F
Länge	300 mm / 11,81"
Art. Nr.	000587

## Anschlussplan

Anschlussplan

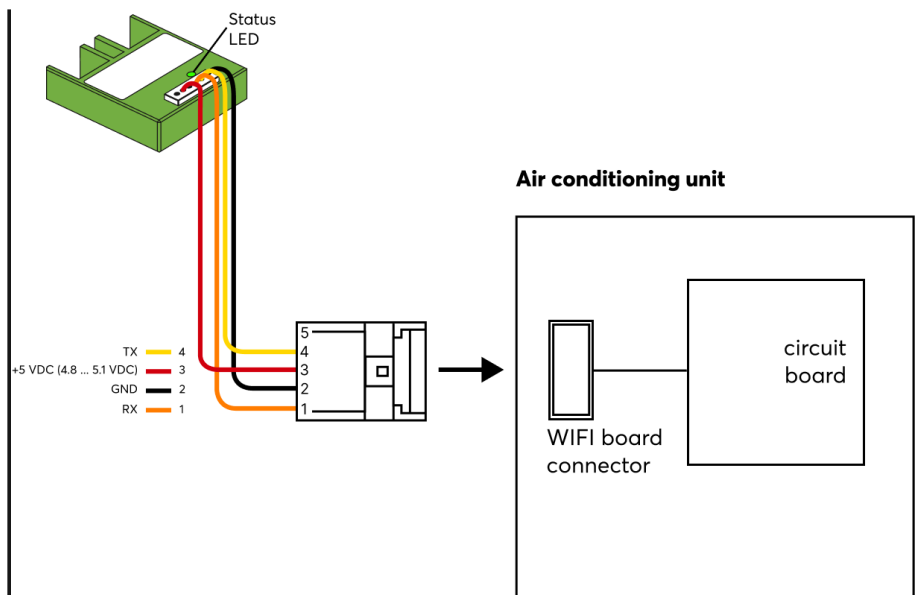

## Produkteigenschaften

Farbe	Grün: RAL 6018
Glanzgrad	Matt

## Gewicht & Abmessungen

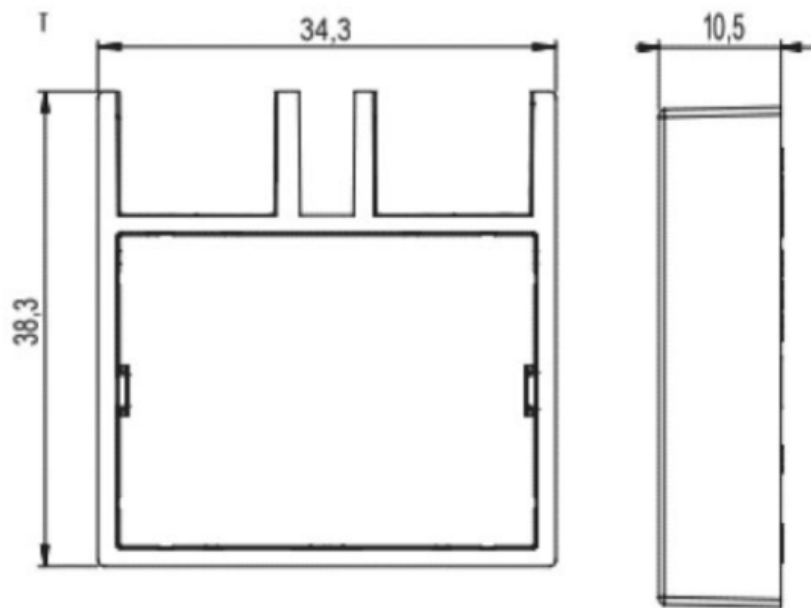
Nettogewicht	54 g
Bruttogewicht	74 g
Produktmaße	38,3 x 34,3 x 10,5 mm / 1,50 x 1,35 x 0,41" (L x B x H)
Produktmaßzeichnung	
Packmaß	79 x 79 x 41 mm / 3,11 x 3,11 x 1,61" (L x B x H)

## Zertifizierungen & Standards

Schutzklasse	IP20
Zertifizierungen	 

Die Installation muss von einer qualifizierten Elektrofachkraft gemäß den einschlägigen Vorschriften durchgeführt werden.

### Veröffentlicht von

Loxone Electronics GmbH  
Smart Home 1  
4154 Kollerschlag  
Austria  
Tel: +43 7287 7070-0  
loxone.com

Loxone UK Ltd.  
The Forum  
Station Road  
Theale, RG7 4RA  
United Kingdom