

LOXONE

Datasheet

Part No: 100561

About the product

Technical Data

Power Supply	9 ... 28VDC
Power consumption	typ. 0.2W, max. 1.7W at display brightness 100%
Power loss	max. 1.7W
Touch area	capacitive touch detection 12/14 touch points
Click feedback	Yes
Temperature detection range	-40 ... 125°C +/- 0.5°C -40 ... 257°F +/- 0.9°F
Humidity detection range	0 ... 100% r. H. +/- 2%, (non condensing)
Ambient temperature	-20 ... 40°C / -4 ... 104°F
Recommended mounting height	135cm / 53.15"

Interfaces

LOXONE Tree	connection with Miniserver / Tree Extension
-------------	---

Ambient Conditions

Humidity	max. 95% r.H. (non condensing)
----------	--------------------------------

Connection Terminals

Terminal type	DG220B
Wire cross-section	0.28 ... 0.8 mm ² / AWG 23 ... 18
Stripping length	5 ... 6 mm / 0.2 ... 0.24"
Temperature resistance	-40 ... 105°C / -40 ... 221°F

Connection Diagram

Connection Diagram

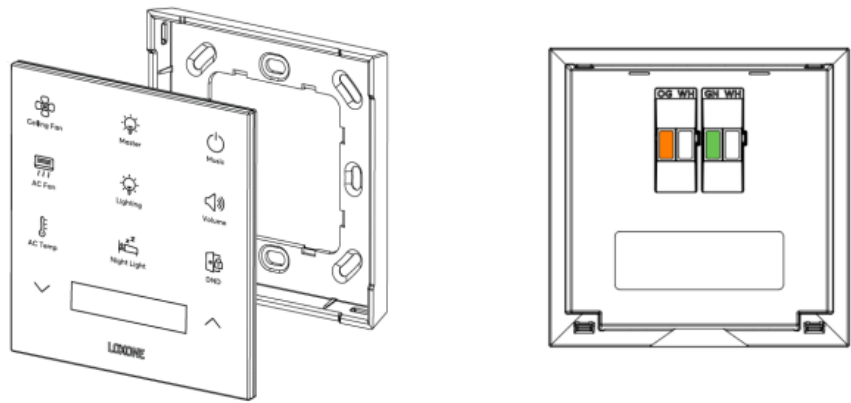

Product Characteristics

Colours | Black: RAL 9005

Finish | Matte

Weight & Dimensions

Net weight | 100 g

Total weight | 142 g

Product dimensions | 90 x 90 x 16 mm / 3.55 x 3.55 x 0.63" (L x W x H)

Pack size | 104 x 107 x 39 mm / 4.09 x 4.21 x 1.54" (L x W x H)

Certifications & Standards

Safety class | IP44

Certifications



Installation must be carried out by a qualified electrician in accordance with the relevant regulations.

Published by

Loxone Electronics GmbH
Smart Home 1
4154 Kollerschlag
Austria
Tel: +43 7287 7070-0
loxone.com

Loxone UK Ltd.
The Forum
Station Road
Theale, RG7 4RA
United Kingdom

Datenblatt

Part No: 100561

Über das Produkt

Technische Daten

Spannungsversorgung	9 ... 28VDC
Leistungsaufnahme	typ. 0,2W, max. 1,7W bei Display Helligkeit 100%
Verlustleistung	max. 1.7W
Tastbereich	kapazitive Berührungserkennung 12/14 Tastpunkte
Klick Feedback	Ja
Messbereich Temperatursensor	-40 ... 125°C +/- 0.5°C -40 ... 257°F +/- 0.9°F
Messbereich Luftfeuchtigkeitssensor	0 ... 100% r. H. +/- 2%, (nicht kondensierend)
Umgebungstemperatur	-20 ... 40°C / -4 ... 104°F
Empfohlene Montagehöhe	135cm / 53.15"

Schnittstellen

LOXONE Tree	Verbindung mit Miniserver / Tree Extension
-------------	--

Umgebungsbedingungen

Luftfeuchtigkeit	max. 95% r.H. (nicht kondensierend)
------------------	-------------------------------------

Anschlussklemmen

Klemmentyp	DG220B
Leiterquerschnitt	0,28 ... 0,8 mm ² / AWG 23 ... 18
Abisolierlänge	5 ... 6 mm / 0,2 ... 0,24"
Temperaturbeständigkeit	-40 ... 105°C / -40 ... 221°F

Anschlussplan

Anschlussplan

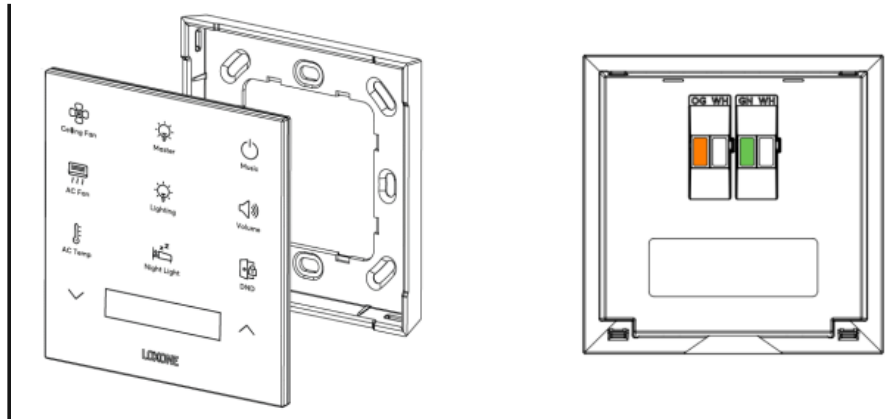

Produkteigenschaften

Farbe Schwarz: RAL 9005

Glanzgrad Matt

Gewicht & Abmessungen

Nettogewicht 100 g

Bruttogewicht 142 g

Produktmaße 90 x 90 x 16 mm / 3,55 x 3,55 x 0,63" (L x B x H)

Packmaß 104 x 107 x 39 mm / 4,09 x 4,21 x 1,54" (L x B x H)

Zertifizierungen & Standards

Schutzklasse IP44

Zertifizierungen



Die Installation muss von einer qualifizierten Elektrofachkraft gemäß den einschlägigen Vorschriften durchgeführt werden.

Veröffentlicht von

Loxone Electronics GmbH
Smart Home 1
4154 Kollerschlag
Austria
Tel: +43 7287 7070-0
loxone.com

Loxone UK Ltd.
The Forum
Station Road
Theale, RG7 4RA
United Kingdom