

Datasheet

Satellite Speaker IP64

Master White

Part No: 610168



About the product

The Satellite Speaker IP64 Master impresses with its excellent audio properties and its **numerous application possibilities**. It is connected directly to an Audioserver or Miniserver Compact via **Tree Turbo** and can transmit the audio signal **to a chain of up to 20 Client speakers**. In this way, it forms a **flexible audio solution** that is scalable for any building size.

Features:

- Countless functions such as text-to-speech, doorbell, alarms or audio notifications
- Music streaming via Bluetooth
- Up to 30m cable length between the clients

Supply and Power

Supply voltage	18...26 VDC
Power consumption	1.5 W (Standby) 35 W (Peak)

Interfaces

LOXONE Tree Turbo	Connection with Audioserver or Miniserver Compact
Master-Client Interface (MCI)	up to 20 speaker clients per Master up to 30m wire length between clients up to 600m total length Wiring: Twisted pair, Line topology
Wireless	Bluetooth: Input V4.2

Audio Specifications

Speaker type	2-Way active speaker
Class-D Amplifier	35W nominal power 70W peak power
Frequency range	48 ... 25000Hz
Crossover frequency	1800Hz
SPL	101dB @ 1m max.
Woofer Ø	140mm / 5.5"
Woofer membrane material	Polypropylene
Tweeter Ø	25mm / 1"
Tweeter dome material	Silk, polymer coated

Ambient Conditions

Temperature	-10...50 °C / 14...122 °F
Humidity	max. 100 % RH (non-condensing)

Connection Terminals

Terminal type	24VDC, Tree Turbo, MCI: WJ332K
Wire cross-section	24VDC, Tree Turbo, MCI: 0.28 ... 1.5mm ² / AWG23 ... 15
Conductor type	24VDC, Tree Turbo, MCI: Stranded / Solid
Stripping length	24VDC, Tree Turbo, MCI: 6mm / 0.24"
Temperature resistance	24VDC, Tree Turbo, MCI: -40 ... 105°C / -40 ... 221°F
Tightening torque	24VDC, Tree Turbo, MCI: 0.4Nm / 0.295 lbf.ft
Connection type	Screw terminals

Connection Diagram

Connection Diagram

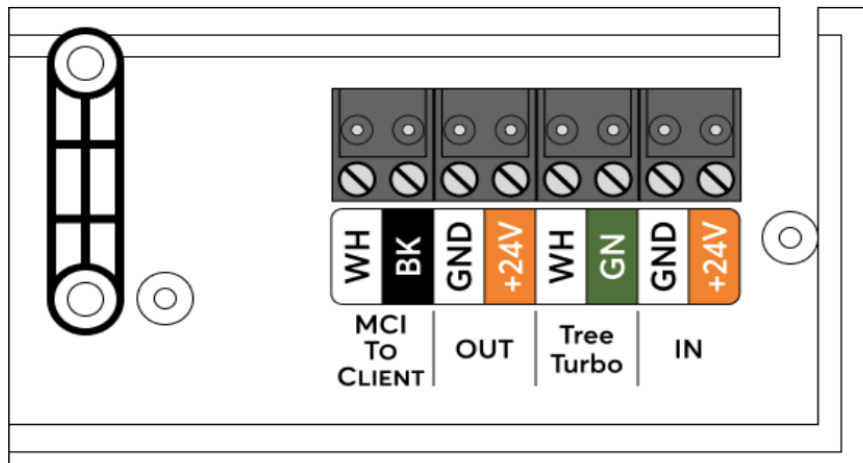

Product Characteristics

Colours White: RAL 9003

Finish Matte

Weight & Dimensions

Net weight 2.65 kg

Total weight 2.89 kg

Product dimensions 216 x 150 x 143 mm / 8.5 x 5.9 x 5.6"

Product dimensions drawing

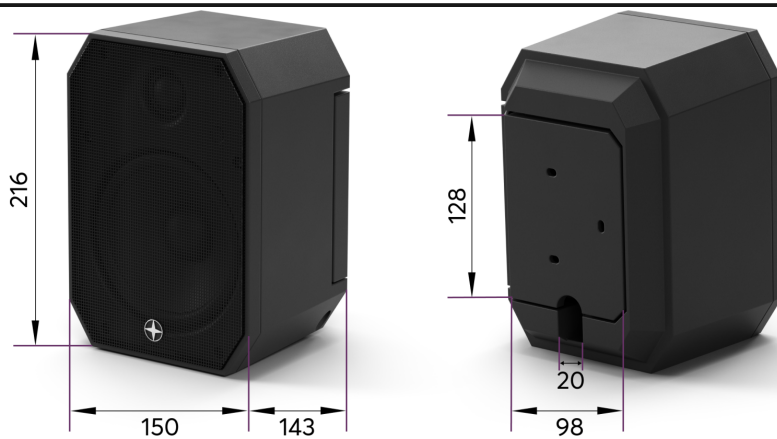

Pack size 250x180x170mm / 9.84x7.09x6.69" (LxWxH)

Certifications & Standards

Safety class IP64

Certifications



Installation must be carried out by a qualified electrician in accordance with the relevant regulations.

Published by

Loxone Electronics GmbH
Smart Home 1
4154 Kollerschlag
Austria
Tel: +43 7287 7070-0
loxone.com

Loxone UK Ltd.
The Forum
Station Road
Theale, RG7 4RA
United Kingdom

Datenblatt

Satellite Speaker IP64

Master weiß

Part No: 610168

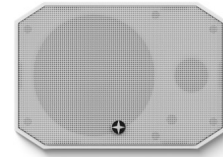

Über das Produkt

Der Satellite Speaker IP64 Master überzeugt durch seine hervorragenden Audioeigenschaften und seine **zahlreichen Einsatzmöglichkeiten**. Er wird direkt über **Tree Turbo** an einen Audioserver oder Miniserver Compact angeschlossen und kann das Audiosignal **an eine Kette von bis zu 20 Client Speakers** übertragen. Auf diese Weise bildet er eine **flexible Audiolösung**, die für jede Gebäudegröße skalierbar ist.

Features:

- Unzählige Funktionen wie Text-to-Speech, Türklingel, Alarme oder Audio-Benachrichtigungen
- Musikstreaming über Bluetooth
- Bis zu 30m Kabellänge zwischen den Clients

Versorgung und Leistung

Versorgungsspannung	18...26VDC
Leistungsaufnahme	1,5 W (Standby) 35 W (Spitze)

Schnittstellen

LOXONE Tree Turbo	Verbindung mit Audioserver oder Miniserver Compact
Master-Client Interface (MCI)	bis zu 20 Speaker Clients pro Master bis zu 30m Kabellänge zwischen den Clients bis zu 600m Gesamtlänge Verkabelung: Twisted Pair, Linientopologie
Drahtlos	Bluetooth: Eingang V4.2

Audio-Spezifikationen

Lautsprecher Typ	2-Wege Aktiv-Lautsprecher
Class-D-Verstärker	35W Nennleistung 70W Spitzenleistung
Übertragungsbereich	48 ... 25000Hz
Übergangsfrequenz	1800Hz
SPL	101dB @ 1m max.
Tieftöner Ø	140mm / 5.5"
Tieftöner-Membranmaterial	Polypropylen
Hochtöner Ø	25mm / 1"
Hochtöner-Kalottenmaterial	Seide, Polymer beschichtet

Umgebungsbedingungen

Temperatur	-10...50 °C / 14...122 °F
Luftfeuchtigkeit	max. 100 % r. F. (nicht kondensierend)

Anschlussklemmen

Klemmentyp	24VDC, Tree Turbo, MCI: WJ332K
Leiterquerschnitt	24VDC, Tree Turbo, MCI: 0.28 ... 1.5mm ² / AWG23 ... 15
Leitertyp	24VDC, Tree Turbo, MCI: Flexibel / Starr
Abisolierlänge	24VDC, Tree Turbo, MCI: 6mm / 0.24"
Temperaturbeständigkeit	24VDC, Tree Turbo, MCI: -40 ... 105°C / -40 ... 221°F
Anzugsdrehmoment	24VDC, Tree Turbo, MCI: 0.4Nm / 0.295 lbf.ft
Anschlussart	Schraubklemmen

Anschlussplan

Anschlussplan

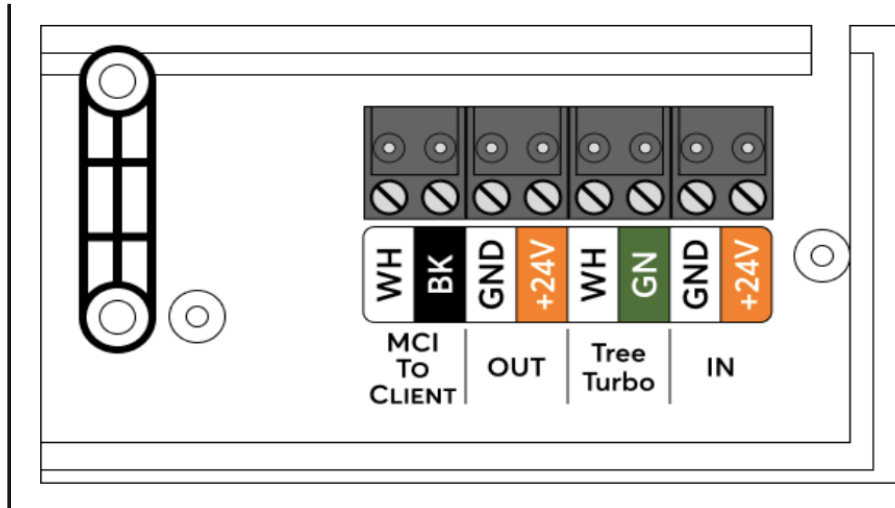

Produkteigenschaften

Farbe Weiß: RAL 9003

Glanzgrad Matt

Gewicht & Abmessungen

Nettogewicht 2,65 kg

Bruttogewicht 2,89 kg

Produktmaße 216 x 150 x 143 mm / 8,5 x 5,9 x 5,6"

Produktmaßzeichnung

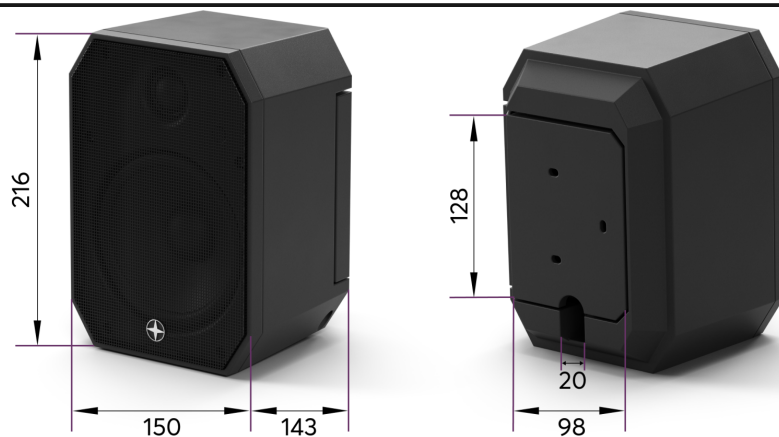

Packmaß 250x180x170mm / 9.84x7.09x6.69" (LxWxH)

Zertifizierungen & Standards

Schutzklasse IP64

Zertifizierungen



Die Installation muss von einer qualifizierten Elektrofachkraft gemäß den einschlägigen Vorschriften durchgeführt werden.

Veröffentlicht von

Loxone Electronics GmbH
Smart Home 1
4154 Kollerschlag
Austria
Tel: +43 7287 7070-0
loxone.com

Loxone UK Ltd.
The Forum
Station Road
Theale, RG7 4RA
United Kingdom